

# COMPARISON OF FLEXURAL CRACKING IN REINFORCED CONCRETE BEAMS WITH DIFFERENT REBAR COATINGS

**Aaron Murphy**, Clemson University, Clemson, SC  
**Sachin Sreedhara**, Clemson University, Clemson, SC  
**Amir Poursaee**, Clemson University, Clemson, SC  
**Brandon E. Ross**, Clemson University, Clemson, SC

## ABSTRACT

*To enhance the corrosion resistance of steel, coated reinforcing bars are used in concrete. This coating can also affect the bond performance and crack size in steel reinforced concrete. This paper presents the results of an experimental program wherein the flexural cracks of concrete beams reinforced with steel bars with different coatings are compared. Specimens with uncoated carbon “black” bars, epoxy-coated bars, galvanized bars, and textured epoxy-coated bars were used in this study. Beam specimens with one of these four types of reinforcements were subjected to a sustained load in 4-point bending for one week. During this time, cracks and displacement were monitored and documented. Then, the beams were loaded to failure to compare their load-displacement responses. The length and width of cracks as well as the number and spacing of cracks were recorded and compared. Consistent with other researchers, the results indicate that epoxy-coated bars have relatively poor bond with concrete and consequently poor crack control. In comparison, the black bars and bars with galvanizing and textured-epoxy coating resulted in better bond and crack control.*

**Keywords:** Rebar coating; flexural cracking; bond strength; sustained load; crack control

## INTRODUCTION

A major issue of reinforced concrete products, such as bridge decks, is corrosion of the steel reinforcement. When the reinforcement corrodes, it results in a decrease in the beam's strength and an increase in crack growth (El Maaddawy 2005). Coatings on the outside of the bars can be used to mitigate corrosion but can also impact the bar-concrete bond and crack control. This paper focuses on the impact of coatings on controlling flexural cracks.

Galvanized steel bars have been proven to have many benefits for corrosion protection. Zinc has a higher chloride threshold compared to steel which is what gives the galvanized bars an advantage in corrosion resistance over uncoated steel bars. Research done on bridges in the United States that are exposed to high levels of accumulated chlorides has shown that bridge decks that use galvanized reinforcement had very low corrosion current densities compared to uncoated steel. A survey of bridges from Iowa, Florida and Pennsylvania showed that after periods of up to 24 years of exposure to marine environments or deicing salts in the winter, galvanized bars only showed signs of superficial corrosion. Another survey from 1991 of marine structures in Bermuda showed that the galvanized coating provided protection to the steel reinforcement even when exposed to chloride levels that exceeded the threshold levels of uncoated steel corrosion (Yeomans 1994).

Epoxy is another coating that has been used as a protection from corrosion for steel reinforcement. A review (Smith, 1996) of investigations from highway agencies in the United States and Canada showed that epoxy-coated steel reinforcement is an effective method to corrosion resistance. The investigations included 92 bridge decks, two bridge barrier rails and one noise barrier rail. In 81 percent of these structures, there was no evidence of corrosion found and the chloride concentrations at the level of the reinforcement were typically at or above the threshold needed to initiate corrosion in steel. In segments where corrosion was found, the corrosion was more severe at areas of heavy cracking, where the concrete cover was shallow or when the concrete had high permeability. It was concluded that when the concrete construction and quality are adequate, then epoxy-coated bars provide effective protection from corrosion.

When a reinforced concrete beam is subjected to bending and the tensile strength of the concrete is exceeded, cracking in the beam occurs. When cracks form in the beam, the reinforcement-concrete bond is interrupted, and the beam experiences a loss in its stiffness. Shortly after a crack is formed, internal cracks start to appear where the steel and concrete bond. These internal cracks cause the bond to deteriorate and more internal cracks form. When this bond is lost, the tensile force cannot be transferred from the steel reinforcement to the surrounding concrete since they are no longer working as a composite unit. This further leads to more loss of stiffness in the beam and higher strain in the steel and eventually to failure (Higgins 2013).

Epoxy coatings have a negative impact on bond with concrete (Choi et al. 1991). Textured-epoxy coated bars have recently been developed to maintain the corrosion mitigation benefits of epoxy coating, but to address the limitation of bond performance. A recent project funded by The Illinois Department of Transportation (IDOT) tested the bond strength of textured-epoxy rebar (Kim 2018). In that study, a pull-out test as well as a flexural test with both standard epoxy and textured-epoxy bars were performed. It was observed that the standard epoxy bar demonstrated an increased tendency to slip and split the concrete. On the other hand, the textured-epoxy bars initially showed

good force-slip behavior. However, the slip resistance was observed to experience a rapid degradation. On average, it was observed that the textured-epoxy bars developed a peak nominal bond stress that was 17% lower than that developed in the traditional epoxy bars.

The objective of the current paper is to compare the crack control performance of uncoated “black”, epoxy, galvanized and textured-epoxy bars when used as flexural reinforcement. The previous study by the IDOT tested the bond of different reinforcing bars using pull-out tests and a flexural load-slip test. This paper adds flexural crack control to the conversation and also includes a comparison with galvanized coating.

## SPECIMEN DESIGN AND CONSTRUCTION

For this experiment, black steel bars were compared with the bars coated with traditional epoxy, galvanized and textured-epoxy bars. The galvanized bars were “continuously galvanized”, a type of coating that provides corrosion resistance and increased ability to bend without compromising the coating (CMC 2020). The textured-epoxy coating was applied in the same manner as traditional epoxy, the only difference being that a textured coat was applied immediately after the smooth coat.

A sustained load test was used, and crack growth and beam displacement were monitored. The sustained load test was a modified version of the Peterman Beam Test (Peterman 2009). The basic concept of the test is a clear span between two supports with a load suspended from the beam at two points. This setup, shown in Figure 1, allows investigation of cracks that form in the concrete. The span length, cross-section and load were designed so that the beam would crack extensively but would not reach flexural failure.

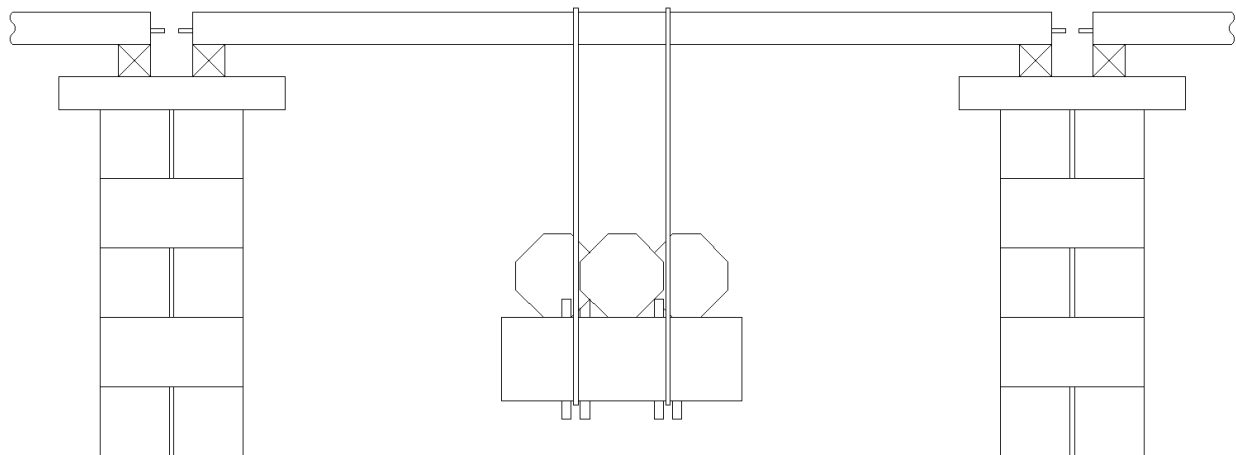

*Figure 1: Schematic illustration of the sustained load setup*

For this project, three series of beams were tested, each with 4 different types of reinforcing bar as shown in Table 1.

Table 1: Variable Matrix

Label	Bar Type	Series #
B1	Conventional Black Bar	1
E1	Epoxy – Coated Bar	1
G1	Galvanized Bar	1
T1	Textured Epoxy – Coated Bar	1
B2	Conventional Black Bar	2
E2	Epoxy-Coated Bar	2
G2	Galvanized Bar	2
T2	Textured Epoxy-Coated Bar	2
B3	Conventional Black Bar	3
E3	Epoxy – Coated Bar	3
G3	Galvanized Bar	3
T3	Textured Epoxy – Coated Bar	3

The beams for the sustained load testing were designed to have a square cross-section of 3.5 inches (90 mm) in each dimension and a length of 93 inches (2360 mm). The reinforcement was a #4 bar ( $\phi = 0.5$  in., 12.7 mm) placed in the center laterally and 1.25 inches (32 mm) from the bottom of the beam to the center of the bar. Figure 2 details this cross-section. A concrete mix typically used by the South Carolina DOT for bridges was used to cast the specimens. The tested 28-day compressive strength was 5070 psi (35 MPa) for series one and 5940 psi (41 MPa) for series two. The reinforcements had slightly different yield strengths but since this project focuses on serviceability, this slight difference was not relevant.

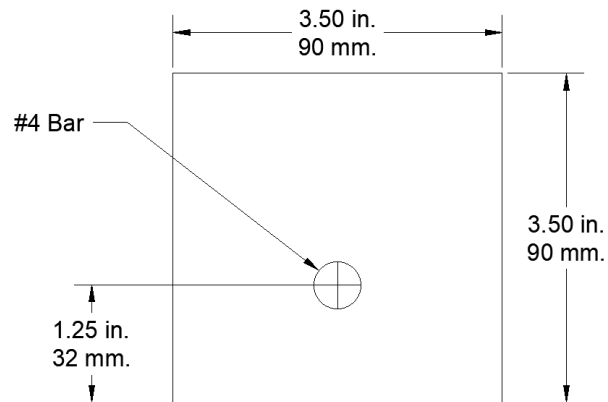

Figure 2: Cross-Section of Specimen

## METHODOLOGY

Each beam was subjected to a sustained load in 4-point bending for one week. The beams had a clear span of 86 inches (2180 mm) and were loaded 41.5 inches (1050 mm) from each end with a total load of 700 lbs. (3.1 kN). Figure 3 shows the setup for the test.



Figure 3: Picture of Sustained Load Setup

Crack growth and displacement were monitored during one week of loading. Displacement was measured at the quarter, mid-span and three-quarter points immediately after loading, after one day and after the full week using a ruler and calipers. After the week, pictures were taken of each crack and analyzed with the ImageJ software (ImageJ 2020) to determine the crack surface area. The deflections and crack sizes changed very little over time and are not discussed further in this paper.

In ImageJ, a digital image was converted to grayscale, as shown in Figure 4b. Having the picture in grayscale enabled the program to isolate the pixels of the crack based on the image being darker in that area. This isolation was done by adjusting the threshold of the image so that it displayed only the crack as shown in Figure 4c. Once the pixels of the crack were highlighted, the program could calculate the area of the crack using the scale provided within the picture. Manual microscope readings of crack width were also collected as a redundant measurement for series one. They were generally consistent with the ImageJ results, but are more subject to human perception and were not used as a primary source of data for comparisons.

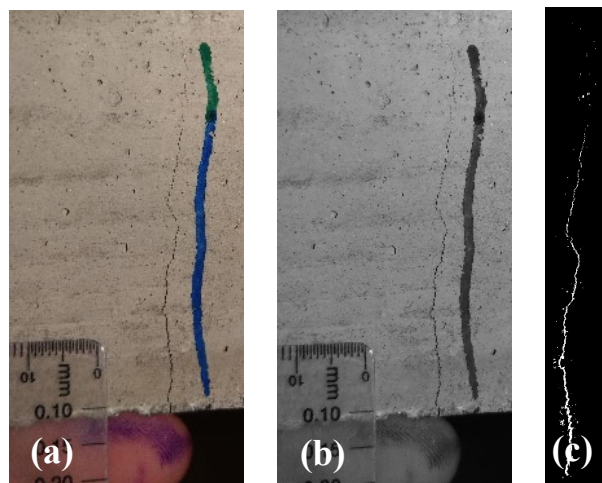

Figure 4: (a) a picture from a crack, (b) crack image in grayscale, (c) crack image processed in ImageJ

The average crack width was measured by taking the crack area and length of each crack from ImageJ and then using Equation 1:

$$\text{Average Width} = \frac{2 \times \text{Area}}{\text{Length}} \quad \text{Eq.1}$$

After the beams were unloaded, they were then tested using a universal test machine (UTM) to further analyze their load-displacement behavior. Each beam was loaded at the same points as in the sustained load test, but supports were positioned 5.5 inches (139.7mm) in from the ends of the beam which differs from the sustained load test where the supports were at the ends of the beam. Figure 5 details the free-body-diagram for this setup.

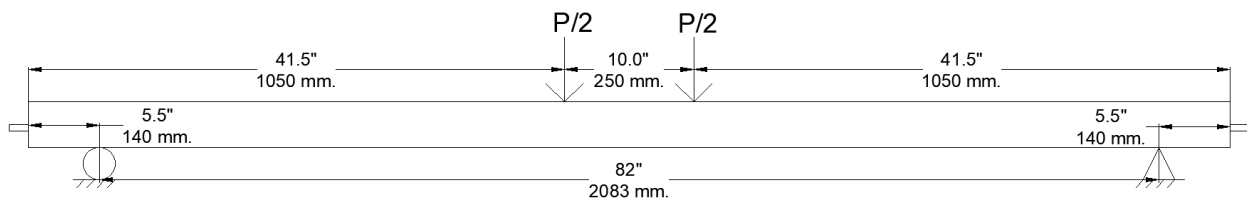

Figure 5: Free-Body-Diagram for Load-Displacement Test

A steel I-beam was placed in the UTM and the beam supports were positioned on each end. The stiffness of the steel I-beam was an order of magnitude greater than the specimen. Hence displacement of the I-beam did not significantly impact the displacements measured from the UTM. The setup for the load-displacement test is shown in Figure 6. Each beam was loaded until it failed. In all cases, failure consisted of concrete crushing at the top of the beam.



Figure 6: Overall View of Load-Displacement Test Setup

The results are presented in terms of a “comparison index”. This is done to normalize the results within each series of specimens to mitigate differences between concrete mixes. While the same mix design was used for both series of specimens, small variations in compressive strength were observed. Normalizing within each series of specimens allows a more direct comparison between the bar types because any effects of difference in the concrete mix are normalized. The comparison index was calculated as follows:

$$\text{Comparison index for specimen } i = \frac{\text{measurement for specimen } i}{\text{average measure of all specimens in same series}} \quad \text{Eq. 2}$$

### RESULTS AND DISCUSSION

In the sustained load test, the total number of cracks, the average width of all the cracks, the average length of all the cracks, the average spacing between each crack and the maximum average crack width were measured. In the case of “# Cracks” the data are presented as the inverse of the comparison index from Equation 2. This is because increased crack quantity is associated with better bar-concrete bond and a higher number of cracks is desirable. In contrast, for all other measures a smaller number/measurement is desirable. Figure 7 and Figure 8 show the results of the four beams in each series.

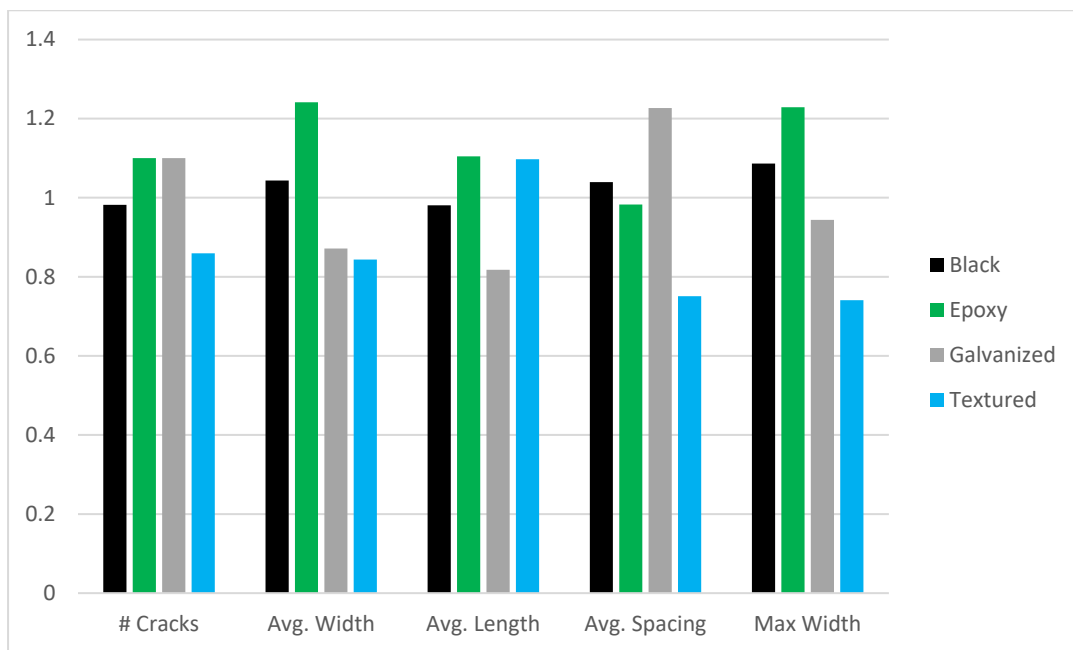

Figure 7: Comparison of Series 1 Crack Data

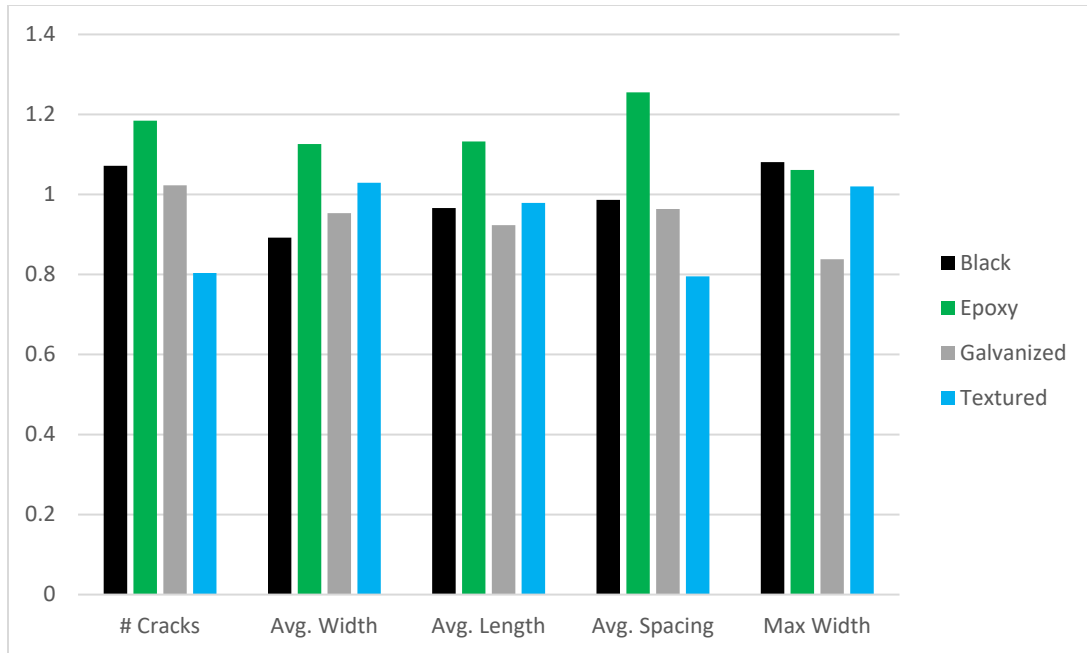

Figure 8: Comparison of Series 2 Crack Data

The number of cracks indicates the distribution of stress between concrete and steel along the beam (Wight 2016). In both series, the textured-epoxy bar resulted in the most cracks and the epoxy bar tended to have the least number of cracks. This result is attributed to superior bond for textured-epoxy bars and worse bond for the traditional epoxy bars.

When the bond is weaker, fewer cracks appear, but these cracks tend to be larger. The average crack width, average crack length and maximum average crack width metrics show how big the cracks tended to be on the beams. The epoxy beams had the highest average crack width in each series. The textured-epoxy and galvanized were fairly similar, except the textured-epoxy bar had a slightly larger average crack width in series 2. The epoxy beams had the greatest maximum average crack width in each series. The average length of the cracks in the epoxy beams was typically the largest. Although, the average crack length in the textured-epoxy beams was similar for series 1. The epoxy reinforcement led to larger cracks meaning that the stress was not distributed as effectively, most likely because of a deterioration in the bond of the reinforcement and the concrete.

The spacing metric measures a similar behavior as the number of cracks on the beams. If there are less cracks, then the spacing between the cracks is larger. This thought follows the data as the epoxy beams had the least number of cracks and also the highest spacing. The spacing of each crack was measured directly on the beam with a measuring tape and then averaged together for each beam in each series.

Figure 9 and Figure 10 show the comparison of load-displacement behavior of the beams. In each series, the galvanized beams had a greater maximum load, and the epoxy beams supported the lowest load. The differences in maximum load are attributed to yield strength of the reinforcement not to the bond performance.



When the bond between the steel reinforcement and the surrounding concrete begins to deteriorate, the stress cannot be transferred from the steel to the concrete as effectively. This results in a loss of stiffness in the beam. The epoxy beam showed the least amount of stiffness compared to the other beams. The beams were already cracked prior to flexural testing in the UTM so the stiffness observed in the tests reflected the existing cracks.

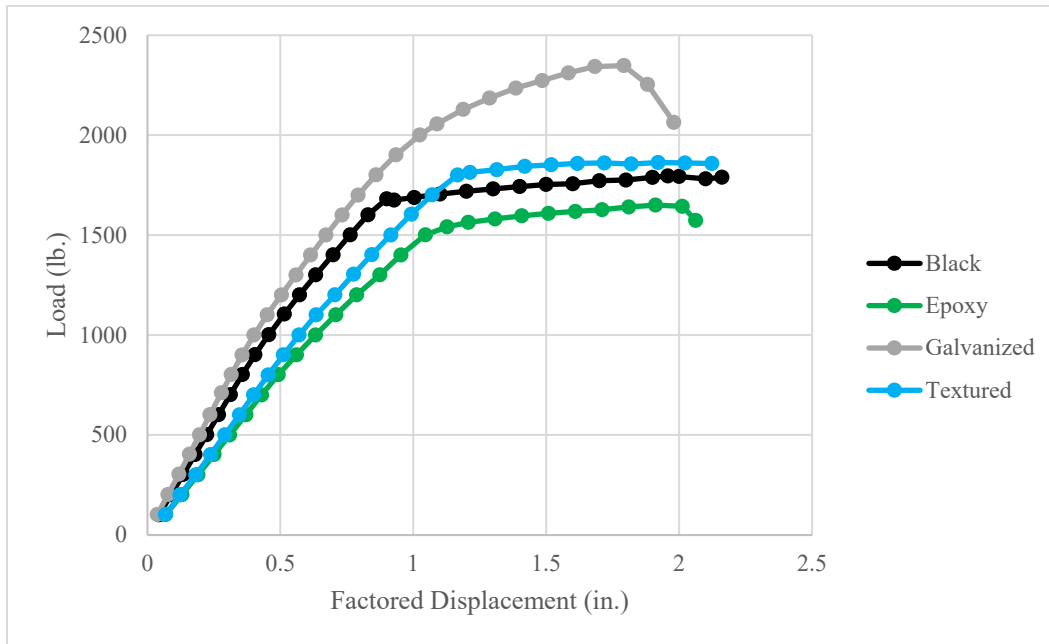

Figure 9: Series 1 Load-Displacement Plot

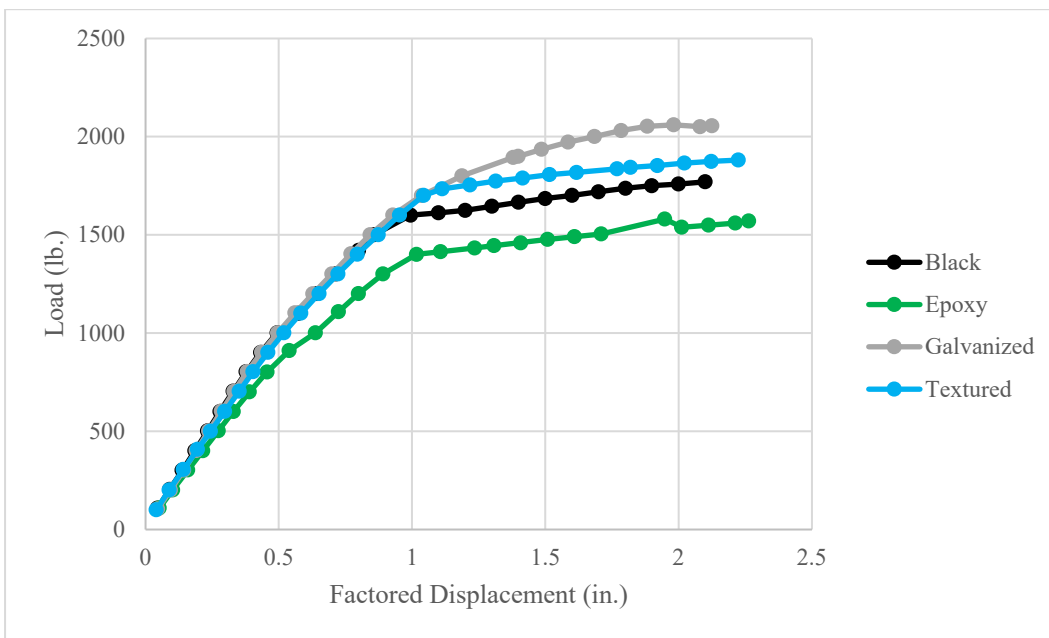

Figure 10: Series 2 Load-Displacement Plot

As a preliminary means of comparing results, the average comparison index values for the specimens and bar types were considered. A higher comparison index value indicates an undesirable response. In the context of this project, a lower comparison index indicates a stronger

bar-concrete bond and/or better crack control. Additional and more sophisticated analyses will be presented in upcoming reporting of the project. Based on the preliminary comparisons, the galvanized and textured-epoxy bars had superior performance relative to the black bars. The epoxy coated bars had the worst performance.

Table 2: Comparison Index Values

	# Cracks	Avg. Width	Avg. Length	Avg. Spacing	Max Width	Displacement at 750 lb.	Average Comparison Index - Specimen	Average Comparison Index - Bar Type
<b>B1</b>	0.98	1.04	0.98	1.04	1.09	0.88	1.00	1.00
<b>B2</b>	1.07	0.89	0.97	0.99	1.08	0.93	0.99	
<b>E1</b>	1.10	1.24	1.10	0.98	1.23	1.22	1.15	1.15
<b>E2</b>	1.18	1.13	1.13	1.25	1.06	1.12	1.15	
<b>G1</b>	1.10	0.87	0.82	1.23	0.94	0.78	0.96	0.95
<b>G2</b>	1.02	0.95	0.92	0.96	0.84	0.94	0.94	
<b>T1</b>	0.86	0.84	1.10	0.75	0.74	1.13	0.90	0.92
<b>T2</b>	0.80	1.03	0.98	0.80	1.02	1.00	0.94	

## CONCLUSIONS

This paper compared the bond strength and crack control behavior of rebars with different coatings in concrete beams. By subjecting the beams to a sustained load for a week, the flexural cracking could be observed and measured. After the sustained load test was completed, the beams were tested in a UTM machine to examine their load-displacement behavior. It was concluded that the traditional epoxy-coated bar had the worst performance among the four reinforcements. The epoxy-coated bar resulted in larger and less frequent cracks when subjected to the sustained load. Further, the epoxy-coated bars showed lower stiffness during the load-displacement tests. Finally, it was concluded that both galvanized and textured-epoxy bars had a relatively higher bond and crack control performance than the uncoated black bars. These results are based on a limited number of samples and are considered preliminary. The results of a third series as well as further analysis are reported (Murphy 2021).

## ACKNOWLEDGEMENTS

This research project is being funded through WisDOT and the USDOT. Neither WisDOT nor the USDOT assume any liability for the contents or the use thereof nor does this presentation reflect official views, policies, standard specifications or regulations of either department.

Clemson students Brianna Crabtree, Grace Crocker, Sam Dodd, Khalil Goodman and Delaney McFarland assisted in specimen construction and testing.

Materials for the project were provided by CMC Commercial Metals, Sherwin Williams and AZZ.

**REFERENCES**

- Choi, O. C., Hadje-Ghaffari, H., Darwin, D., & McCabe, S. L. (1991). Bond of epoxy-coated reinforcement: Bar parameters. *ACI Materials Journal*, 88(2), 207-217.
- CMC Commercial Metals website. Accessed October 2020. <https://www.cmc.com/en-us/what-we-do/america/mill-products/galvabar>
- El Maaddawy, T., Soudki, K., & Topper, T. (2005). Long-term performance of corrosion-damaged reinforced concrete beams. *ACI Structural Journal*, 102, 649-656.
- Higgins, L., Forth, J. P., Neville, A., Jones, R., & Hodgson, T. (2013). Behaviour of cracked reinforced concrete beams under repeated and sustained load types. *Engineering Structures*, 56, 457-465.
- Kim, K. E., & Andrawes, B. (2018). *Behavior of epoxy-coated textured reinforcement bars*. University of Illinois at Urbana-Champaign: Illinois Center for Transportation.
- ImageJ: National Institutes of Health, Accessed July 2020, <http://rsbweb.nih.gov/ij/>.
- Murphy, A. J. (2021). Comparison of Flexural Cracking in Reinforced Concrete Beams with Different Rebar Coatings (16301) [Master's Thesis, Clemson University].
- Peterman, R. J. (2009). A simple quality assurance test for strand bond. *PCI Journal*, 143-161.
- Smith, J.L. and Virmani, Y.P. (1996). *Performance of epoxy coated rebars in bridge decks* (Final Report No. FHWA-RD-96-092). McLean, Virginia: Federal Highway Administration.
- Wight, J. K. (2016). *Reinforced concrete mechanics and design* (Seventh ed.) Pearson.
- Yeomans, Stephen. (1994). Performance of Black, Galvanized, and Epoxy-Coated Reinforcing Steels in Chloride-Contaminated Concrete. *Corrosion*. 50. 72-81. 10.5006/1.3293496.