

## CEMENT-BASED BEARING PADS FOR BEAM-TO-COLUMN CONNECTIONS OF PRECAST CONCRETE STRUCTURES

**Mounir K. El Debs, PhD**, Dept. of Structural Engineering, University of S. Paulo, Brazil

**Ellen K. Bellucio, MS**, PhD student, University of S. Paulo, Brazil

**Ana Lucia El Debs, PhD**, Dept. of Structural Engineering, University of S. Paulo, Brazil

### ABSTRACT

*Bearing pads are used in precast concrete connections to avoid stress concentration in the contact area between precast elements. Typically, the bearing pads are made of chloroprene rubber, which is a highly deformable material. Bearing pads made of this material prevent concentration of compressive stresses while also allowing horizontal displacements and rotations of the beam on the column. This paper presents a bearing pad made of cement-based composites, with an intermediate behavior between chloroprene rubber and direct contact between precast elements. The bearing pad material is an ordinary cement mortar containing latex, short fibers and lightweight aggregate. These ingredients aim to reduce the modulus of elasticity and also to provide high toughness composites, due the bearing pad purpose. This paper presents the results of material characteristics obtained from cylindrical samples, as well as monotonic and cyclic tests with uniform compression on bearing pads. Studies of two precast concrete connections with this type of pad are presented. The studies included testing on connections prototypes and numerical simulations of typical precast concrete structures to compare their structural behavior with the behavior obtained using chloroprene rubber pads. The first study deals with single-story structure, while the second one focuses on a low rise multi-story structure. The results show that the stiffness provided by the developed bearing pads to the connection produces a significant reduction in the structure's deflections and, in the case of multi-story structure, a great benefit in the distribution of bending moments can be obtained.*

**Keywords:** Bearing pads, Connections, Precast concrete

## INTRODUCTION

According PCI<sup>1</sup>, bearing pads are used to distribute concentrated loads and reactions over the bearing area. Several materials are used for bearing pads. The most common bearing pad used in beam-to-column connections is the elastomeric pad, which is made of chloroprene. Chloroprene is highly deformable and therefore compensates for the irregularities of the concrete surface. This promotes a more uniform distribution of contact stresses and allows relative movements between precast elements. The ability to accommodate relative movements is essential because length changes in the elements, such as those due to thermal effects, would otherwise introduce restraint load into the structure. On the other hand, this type of pad can result in structures with a high level of flexibility.

This paper deals with a proposal of Cement-Based Bearing Pads (CBBP) for precast concrete connections with an expected intermediate behavior between chloroprene and direct contact. As the bearing pads of cement-based material would be more rigid than the elastomeric pad, it can lead to more stiff structures and also be used in case of high level compressive stresses. On the other hand, the effects of length changes on the precast components must be taken into account more carefully.

This type of bearing pad has been previously studied (Barboza et al.<sup>2</sup>; El Debs et al.<sup>3</sup> and El Debs et al.<sup>4</sup>). Figure 1 shows an experimental example of its use in Brazil. .

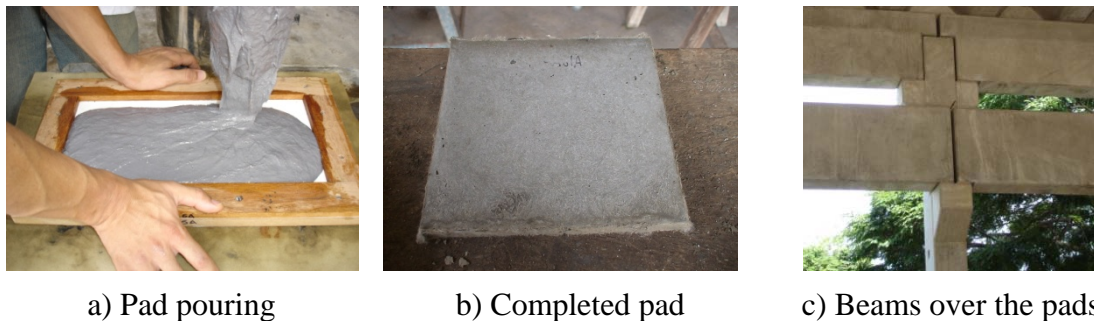

Fig. 1 Experimental application of beam to support an overhead crane of 60 kN

The goal of this paper is to present some studies on cement-based material, bearing pads with this material and two precast concrete connections with this type of pad. The first study deals with single-story structure, while the second one focuses on a low rise multi-story structure.

## PROPOSED BEARING PADS

### THE CEMENT-BASE MATERIAL

The purpose of this study is to obtain a cement-based material with characteristics of greater deformability and higher toughness, compared to ordinary cement-based materials, to be used in the bearing pads.

These characteristics are necessary for the bearing pads to accommodate irregularities of the concrete surface and to transmit a uniform distribution of stresses.

The material can be obtained from Portland cement and sand mortar incorporating the following ingredients: a) soft aggregate or an additive to entrain air in the mixture, b) latex, and c) short fibers.

The soft aggregate (e.g. vermiculite) or air entraining agent significantly increase the deformation capacity of the material in the hardened state. Due to the presence of surfactants used in the production of the latex, a significant amount of air can be incorporated into the mixture, also increasing the deformation capacity of the material. The addition of short fibers to the concrete increases its toughness. In large quantities, the fibers reduce the workability of the mixture and can incorporate air into the hardened material, reducing its modulus of elasticity.

Several studies had been done to get mixtures with reduced modulus of elasticity, but with acceptable compressive strength (Barboza et al<sup>2</sup>; El Debs et al<sup>3</sup>; El Debs et al<sup>4</sup> and Siqueira<sup>5</sup>. First studies presented in Barboza et al<sup>2</sup> and El Debs et al<sup>3</sup> leads to a basic mixture with cement/aggregate ratio of 0.3 and cement/water ratio of 0.4 were fixed to obtain minimum compressive strength of about 20MPa.

#### STUDIED MIXTURES

El Debs et al<sup>4</sup> presented a study with a large amount of mixtures. In this study, early strength Portland cement and river sand with maximum diameter of 2.4 mm were used.

The soft aggregate was small-sized (maximum diameter of 2.4 mm) thermo-expanded vermiculite, with specific mass of 0.173 kg/dm<sup>3</sup>. The latex was Styrene-butadiene polymer, SB 112, with solid amount of 50% and specific mass of 1.02 kg/dm<sup>3</sup> at 25°C.

Two types of fibers were used: a) PVA (polyvinyl alcohol) fiber and b) Cem-FI glass fiber. The PVA fibers had 12 mm of length, equivalent diameter of 0.2 mm and specific mass of 1.3 kg/dm<sup>3</sup>. The glass fibers were also 12 mm long with diameter of 0.014 mm, as indicated by the manufacturer, and specific mass of 2.55 kg/dm<sup>3</sup>. A superplasticizer was used for the mixtures with a great amount of vermiculite.

Nineteen mixtures were chosen for this study. Cylindrical samples of 50 mm of diameter and 100 mm of height were used to determine the compressive strength and the modulus of elasticity. The compressive strength given by average of 4 samples is shown in Figure 2. The notation used in this figure and the other parts of this text is: VaBcLd where V means Vermiculite, a is the amount of vermiculite in percentage of the total aggregate mass, B is the type of fiber (P for PVA and G for glass), c is the fiber volumetric rate in %, L means Latex and d is the amount of latex in percentage of cement mass. The term REF means the reference mixture, that is, the mortar without vermiculite, fibers and latex.

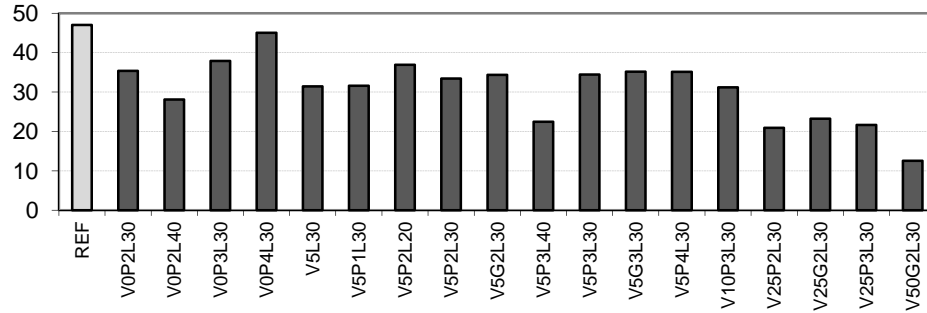

Fig. 2 Compressive strength (El Debs et al<sup>4</sup>)

These mixtures were chosen based on the following aspects: a) a mixture with 5% of vermiculite, 3% of PVA fiber and 30% of latex was fixed as a basic mixture, and the other mixtures were variations of this basic one; b) the proportion of vermiculite and sand was limited to practically 25%; the proportion of 50% aims to complete the reference; c) in principle, the more the amount of fibers included in the mixture, within appropriate limits, the better the material behavior; previous studies indicate that 3% to 4% PVA fibers ratio can be reached; other values complete this study; d) the amount of 30% of latex was employed in early studies based on the information that larger amounts decrease the compressive strength; other amounts, 40% and 20% were also used to analyze this variable. Figure 3 presents the modulus of elasticity given by the average of 3 samples.

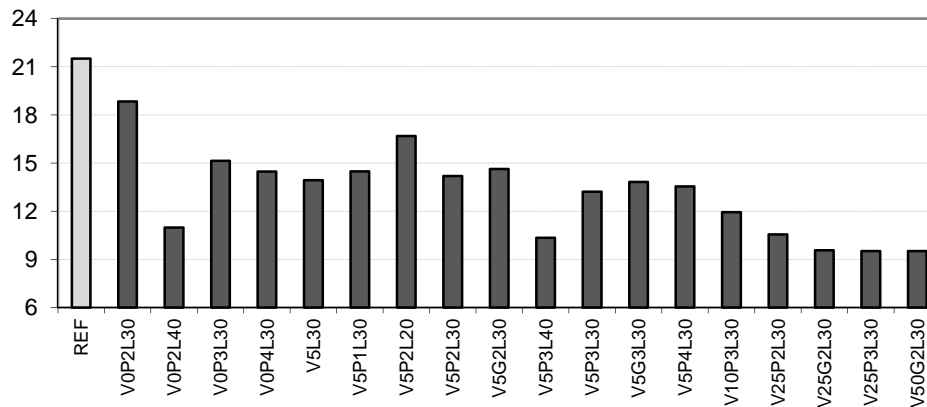

Fig. 3 Modulus of elasticity (El Debs et al<sup>4</sup>)

The values of compressive strength and modulus of elasticity indicate that: a) a larger amount of vermiculite decreases the modulus of elasticity, but also decreases the compressive and tensile strengths, b) if a limit of 20 MPa compressive strength is established, the amount of vermiculite cannot exceed 25% of sand mass, c) the reduction of strength due to latex addition becomes expressive when the amount of latex reaches 40%, suggesting a limit of 30% for the latex amount; e) the amount of fibers had little consequence on the modulus of elasticity, while for the compressive strength it was insignificant.

Siqueira<sup>5</sup> presents other study with the same materials, but with different type of fiber. In this study, a 20  $\mu\text{m}$  diameter fibrillated polypropylene fiber was specially cut to be 6.0 mm in length to promote a high incorporation rate in the composite.

Using the same sample dimensions, amounts and procedures, the compressive strength and the modulus of elasticity were determinate. Figures 4 and 5 show the results for each mixture. The notation is analogue. The fiber in the case is polypropylene and its notation is PP. In this study, the amount of latex was fixed in 30%. As the amount of latex is constant, it was not included in the notation.

From the tests results, it can be seen that with an increase in vermiculite quantity and consequent a decrease in fiber quantity, there is a decreasing trend of compressive strength and elasticity modulus. The results obtained in this research agree with previous one, in spite of some differing values, which can be attributed to the use of different cement batches.

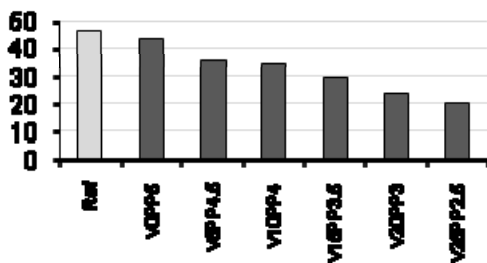

Fig. 4 Compressive strength (Siqueira<sup>5</sup>)

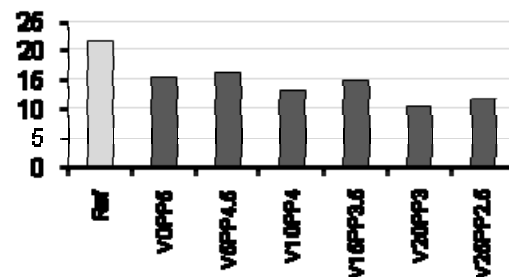

Fig. 5 Modulus of elasticity (Siqueira<sup>5</sup>)

If the mixtures without vermiculite, with 50% of vermiculite, with 40% of latex and with 20% of latex were discarded, the following values would be representative of the proposed material: 20 to 45 MPa for compressive strength and 10 to 15 GPa for modulus of elasticity.

#### CBBP UNDER UNIFORM LOAD

The CBBP were subjected to load applied by the plates of a universal test machine. The objective of this test is to determine the deformation capacity of the CBBP when subjected to uniform compressive stresses.

Besides the CBBP, El Debs et al<sup>4</sup> presents chloroprene bearing pads. Two types of wood bearing pads were also included, as they are generally used in the storage of precast elements. Wood 1 (Pinus Taeda) is a soft one and wood 2 (Eucalyptus Citriodora) has an intermediate rigidity. The chloroprene and wood bearing pads provide a reference for the analysis of the bearing pads with the proposed material.

The main variables for these tests were the mixture, the bearing pads thickness and the bearing pads area. The thicknesses were 5 mm, 10 mm and 20 mm. The areas were 150 mm

x 150 mm and 100 mm x 100 mm. Only the results of 150 mm x 150 mm are present in this paper.

The tests were performed in a universal machine with 2500 kN capacity in compression. The load was applied at 5 kN/s rate.

Figure 6 presents a typical stress x strain curve. As the initial portion of the curves includes the initial accommodation of the bearing pads, the bearing pads rigidity could be determined by the expression:

$$R = \sigma / (\Delta h / h) \quad (1)$$

where  $\sigma$  is stress applied,  $\Delta h$  is bearing pads deformation and  $h$  is bearing pads thickness.

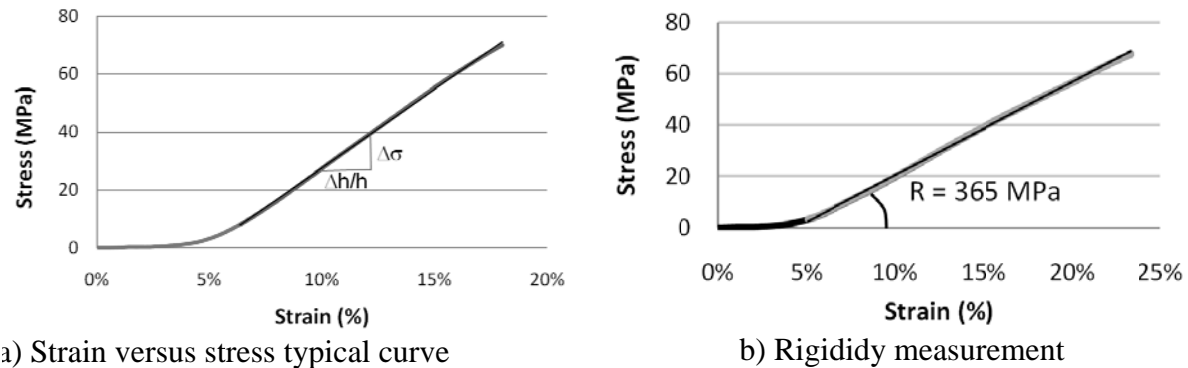

Fig. 6 Bearing pad rigidity evaluation (100mm x 100mm x 20 mm - mixture V5P3L30)

Table 1 presents the bearing pads rigidity and the bearing pads deformation for stress level of 25 MPa, whose values correspond to the average of two samples. It must be pointed that: a) the load was applied until 1800kN for bearing pads of 150 mm x 150 mm, corresponding to a stress of 80 MPa, since the bearing pads are confined in the machine plates, b) the stress of 25 MPa was fixed to compare the bearing pads deformation and c) the bearing pads deformation included the initial part of the curves, as showed in Figure 6.

From the results of table 1 it can be observed that: a) as expected, the bearing pads rigidity decreases with the increase of vermiculite amount, b) when the thickness increases the bearing pads rigidity increases for the proposed material and wood, but for the chloroprene bearing pads the opposite occurs.

The chloroprene bearing pads have a peculiar behavior, associated with the shape factor that corresponds to the relationship between the support area and the lateral area.

The CBBP does not change its shape. Thus, the bearing pads rigidity was expected to be independent of the bearing pads thickness, which did not occur. This fact suggests that a CBBP submitted to uniform load presents an accentuated deformation for small loads

because the stresses concentrate in some points on the surface. This behavior corresponds to the initial part of stress x strain curves. Increasing the load, there will be more points, but the load transfer remains in discrete points of the contact.

Table 1 Rigidity and deformation of the 150 x 150 mm bearing pads (El Debs et al<sup>4</sup>)

Mixture	h=5 mm	h=10 mm	h=20 mm	Mixture	h=5 mm	h=10 mm	h=20 mm
Rigidity (MPa)				Deformation (mm) at stress of 25 MPa			
V5P2L30	224	442	724	V5P2L30	1.360	1.490	1.760
V5G2L30	228	440	731	V5G2L30	1.350	1.470	1.780
V5P3L30	240	447	728	V5P3L30	1.390	1.540	1.800
V5G3L30	244	453	734	V5G3L30	1.410	1.550	1.790
V5P4L30	256	461	750	V5P4L30	1.440	1.650	1.840
V10P3L30	202	337	531	V10P3L30	1.690	1.840	2.000
V25P2L30	165	226	402	V25P2L30	1.850	2.390	3.970
V25G2L30	169	224	410				
Elastomer	-	73	38				
Wood 1	-	68	126				
Wood 2	-	144	283				

The study presented in Siqueira<sup>5</sup> includes only bearing pads of 150 mm x 150 mm and thickness of 10 mm and the fibers used were polypropylene. Other conditions are the same. On the other hand, this study presents also cyclic load besides the monotonic load presented in the previous study. Table 2 shows the results of rigidity and deformations at the stress of 25 MPa

Figure 7 shows a typical cyclic stress versus strain curve. For the first phase of cyclic test, another two pads of each mixture were tested under a total of 200 cycles. The compressive load was applied at the same strain rate and using 50 cycles for each stress level of 2.5, 5.0, 10.0 and 20.0 MPa. In a subsequent phase, another two samples of each mixture were tested with 300 cycles of loading for each stress level. The protocol for load application was identical to the previous one, but 300 cycles were applied instead of 50 load cycles, implicating on a total of 1200 cycles.

From the monotonic loading test results it can be noticed that the pad rigidity decreases as the amount of vermiculite increases, and consequently it decreases with the amount of fiber, as in the previous study.

From the cyclic loading tests it can be observed that the bearing pads present a plastic deformation for the first cycle to a stress level of 2.5 MPa. After this plastic deformation, the bearing pad rigidity remains almost constant into all cycles of the same level of stress. Additionally, it is observed that the curves from the last load cycle of 20 MPa stress level do

not exhibit appreciable plastic deformation or rigidity deterioration, showing the resilient capacity of the described mixtures.

Table 2 Average CBBP rigidity and deformation for monotonic tests (Siqueira<sup>5</sup>)

Mixture	Rigidity (MPa)	Deformation (mm)
V5PP4.5	388	1.255
V10PP4	351	1.535
V15PP3.5	335	1.305

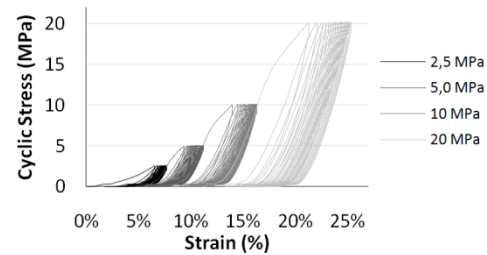

Fig. 7 Cyclic stress versus strain curve for the V10PP4 mixture (1200 cycles).

After the cyclic tests, a visual inspection of each bearing pad was performed, and the samples did not present any damage, even after being subjected to high levels of compressive stress during these tests (i.e., 20 MPa is twice the maximum service compression stress for chloroprene bearing pads). They presented only crushing in the surface imperfections due to the fabrication process and small cracks in the corners. Therefore, it is concluded that the proposed mixtures are adequate for bearing pads subjected to stresses levels up to 20 MPa.

## APPLICATION EXAMPLE: PORTAL FRAME

### STRUCTURAL SYSTEM

This case focus a structure with single-story and large spans, which is used in industries, commerce, and similar. Normally, beam-column connection is made with chloroprene bearing pad and bolts. Figure 8 shows examples of this type of connection. Usually, this connection is considered pinned one.

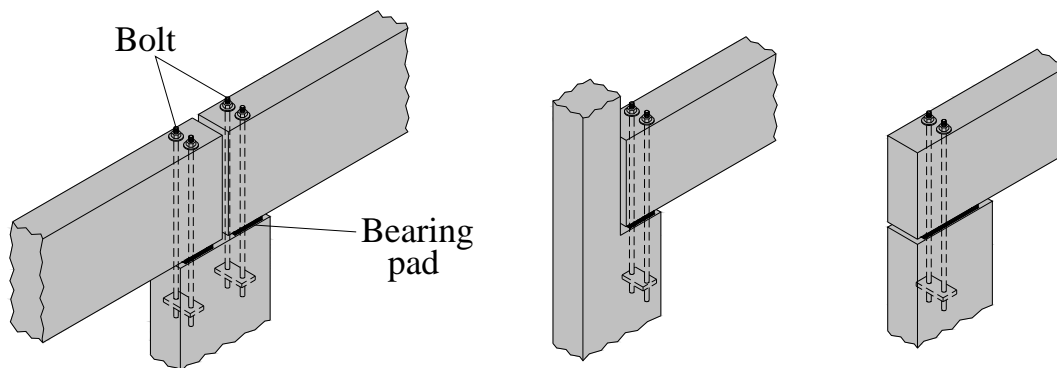

Fig. 8 Used connection variations

One benefit of cement-base bearing pad is to provide stiffness and strength to the connections regarding the chloroprene, which is supposed pinned.



## EXPERIMENTAL PROGRAM

An experimental program with 4 half-scale models was performed to determine the rigidity and strength for this type of connection. Figure 9 shows the used model and Table 3 presents the main characteristics of the models. All CBBP were made with V5G2L30 mixture and thickness of 10mm. Two bolts of 12.5mm diameter placed in the middle of the CBBP were used in all models. Figure 10 presents photos of model. The complete description of this experimental program is presented in Sawasaki<sup>6</sup>.

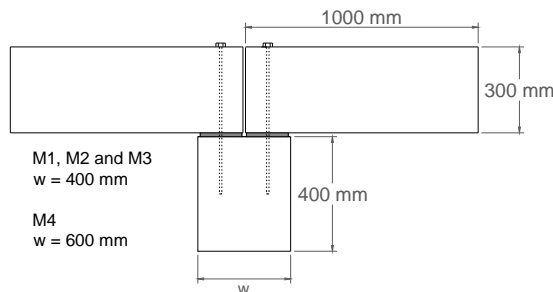

Fig. 9 Model geometry

Table 3 Models characteristics

M	Bearing Pad (mm x mm)	NYS (MPa)	Type of Bearing pads
1	150 x 150	250	Cement-Base
2	150 x 150	250	Chloroprene
3	150 x 150	500	Cement-Base
4	250 x 150	500	Cement-Base

M - Model; NYS - Nominal yield strength of bolts



Fig. 10 Model close-up before and Models under test in inverted position.

Figure 11 shows the envelope of bending moment versus connection rotation. These results in the initial parts of the curves show that CBBP can provide a strength and, mainly, rigidity to the connections.

## NUMERICAL SIMULATION

Figure 12 shows the structure scheme with the loads. A commercial software was used for the numerical analysis with frame elements.

Based on experimental results, an extrapolation was done to evaluate the connection rigidity with CBBP and the obtained values are: 4.20 MNm/rad for 2 bolts and 9.62 MNm/rad for 4 bolts.

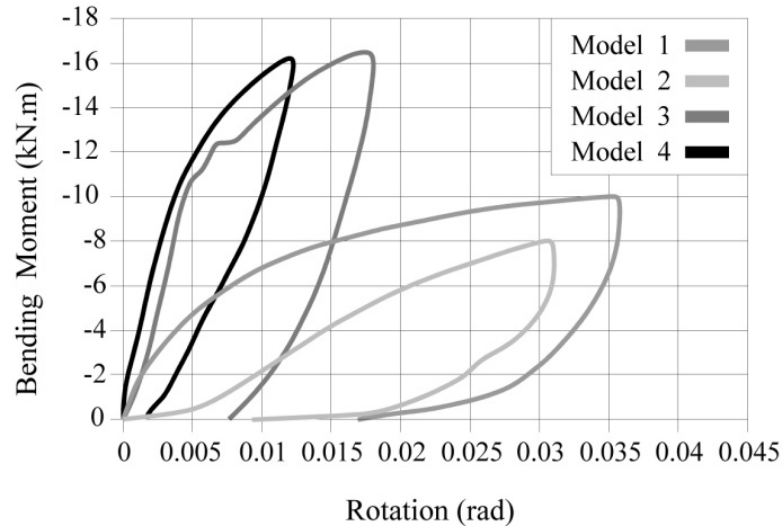

Fig. 11 Bending moment versus connection rotation

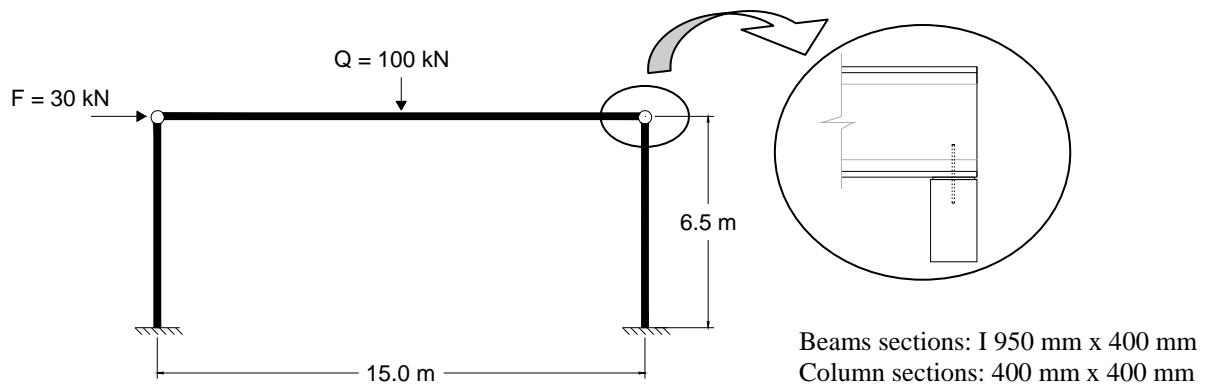

Fig. 12 Structure scheme and the applied loads

The following cases were performed: a) pinned connection under lateral and vertical load, b) semi-rigid connection with 2 bolts under lateral and vertical load, c) semi-rigid connection with 2 bolts under vertical load, d) semi-rigid connection with two bolts, with only lateral applied load, e) semi-rigid with four bolts under lateral and vertical load, (f) semi-rigid, four bolts, under vertical load, and (g) semi-rigid, four bolts, under lateral load.

Table 4 and Table 5 show the representatives bending moments and deflections, respectively. The percentages refer to the case considered pinned connection. It can be observed that the bending moment reduction in the base of the columns and the deflection at the top of the column are quite significant, reaching, for connection with four bolts, the reductions of 21.8% for the bending moment and 32.8% for the lateral deflection, regarding the pinned one. The bending moment in the mid-span of the beams can be reduced by 12.4% and the vertical deflection can be reduced by 18.6%, when the semi-rigidity is taken into account.

Table 4 Bending moment at base of the columns and the mid-span

	Pinned Q+F (a)	2 Bolts Q+F (b)	4 Bolts Q+F (c)	2 Bolts F (d)	4 Bolts F (e)	2 Bolts Q (f)	4 Bolts Q (g)
average at base of the columns (kN.m)	97.5	84.5	78.0	84.5	76.2	12.9	23.2
%		-13.3	-20.0	-13.3	-21.8		
mid-span of the beams	375	349	330	0	0	349	328
%		-6.9	-11.8			-6.9	-12.4

Table 5 Deflections at top of the columns and at the mid-span of the beam

	Pinned Q+F (a)	2 Bolts Q+F (b)	4 Bolts Q+F (c)	2 Bolts F (d)	4 Bolts F (e)	2 Bolts Q (f)	4 Bolts Q (g)
Average at the top of columns (mm)	19.4	15.5	13.6	15.5	13.0	0.0	0.0
%		-20.0	-30.0	-20.0	-32.8		
Mid-span of the beams (mm)	39.4	35.3	32.4	0.0	0.0	35.3	32.1
%		-10.3	-17.6			-10.3	-18.6

## APPLICATION EXAMPLE: MULTI-STORY STRUCTURE

### STRUCTURAL SYSTEM

This example deals with a low rise multi-story structure. Usually, the connections are made with chloroprene pad and bolts and the structure is designed with pinned connections. In this case, besides the replacement of the chloroprene pads by CBBP, it is proposed fulfilling by grout of the space between the upper part of the beam and the column, as showed in the Figure 13

These alterations do not change the connection regarding aesthetic and involved tolerances. Regarding the manufacture, there is an additional job to fulfill the space between the beam and the column.

Regarding the structural behavior, it is expected a partial transmission of bending moment, which would be larger for negative bending moment and smaller for positive one. For the beam design, these transmissions of bending moments produce a reduction of the positive bending moment of the beam, for the load applied after the connection becomes effective. For the column design, these transmissions of bending moments, even partial, would reduce significantly the bending moments in the column, compared with the pinned connection

design. The column bending moments reduction leads to a decrease of the column cross section dimensions for the same height of structure, or, for the same cross section of the column it could be got higher structures.

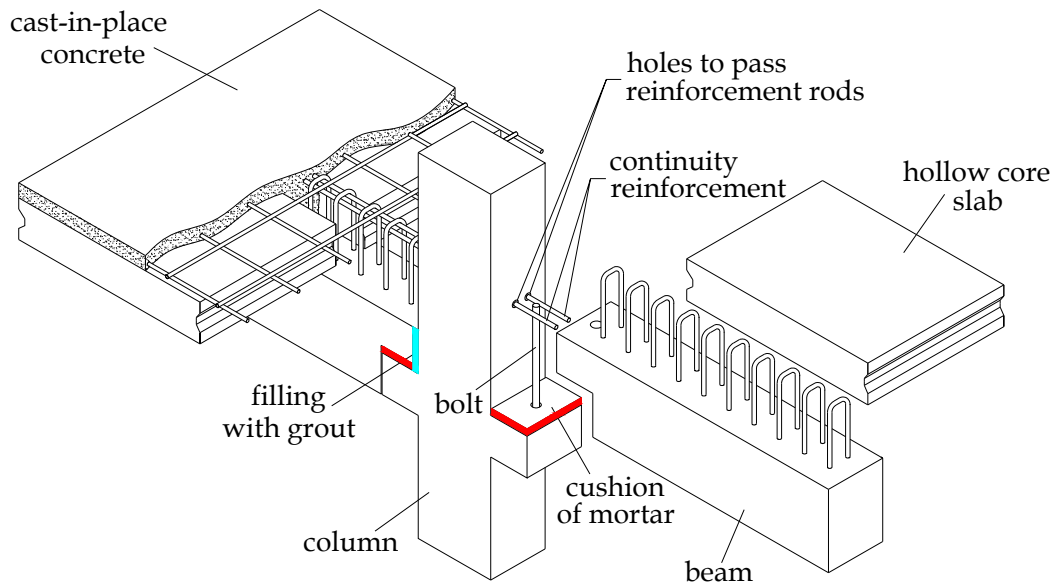

Fig. 13 The modified beam-column connection

## EXPERIMENTAL PROGRAM

The experimental program included two prototypes. Prototype 1 corresponds to an internal column of the structure, and Prototype 2 represents an external column of the structure. Figure 14 presents the geometry and details of tested prototypes and Figure 15 shows photos of the prototypes manufacture.

Experimental program is detailed in El Debs et al<sup>7</sup>. The synthesis result is presented in the figure 16a, with the bending moment envelopes versus rotation. Figure 17 shows a proposed curve to represent the behavior of the connection whose parameters are the ultimate bending moment and connection rigidity.

Based in this study, models were proposed to determine the ultimate bending moments and the rigidity of this type of connection in El Debs et al<sup>8</sup>.

## NUMERICAL SIMULATION

In order to evaluate the influence of the connection rigidity on the structure behaviour, numerical simulations of a typical multi-story building with connections of different grades of rigidity were performed.

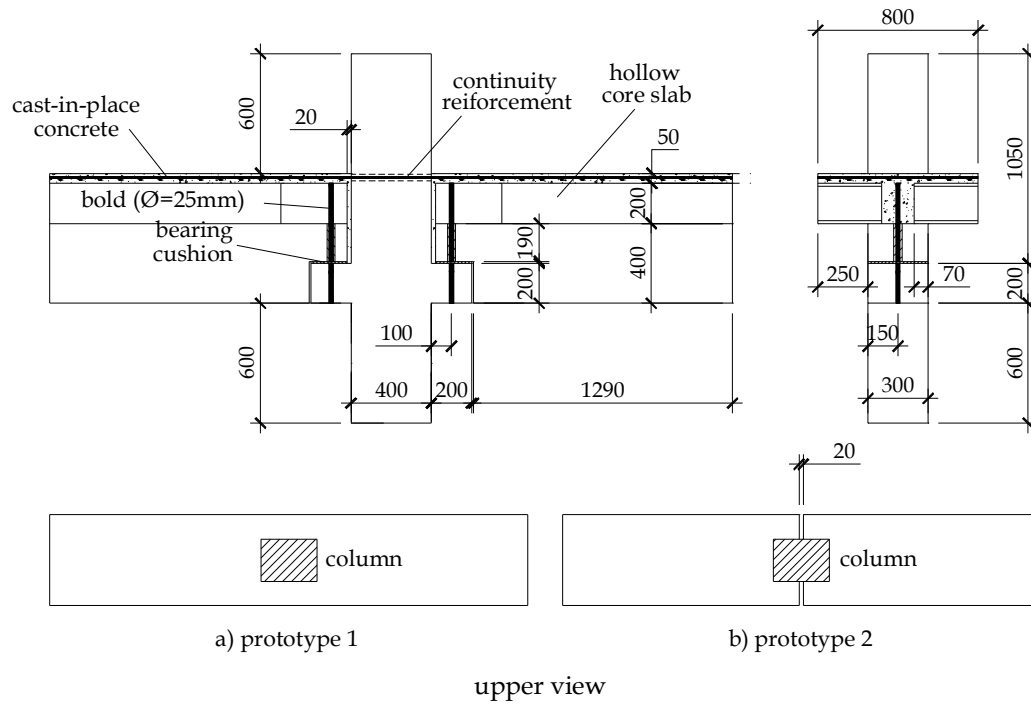

Fig. 14 Geometry and details of tested prototypes



Fig. 15 Photos of the prototype manufacture

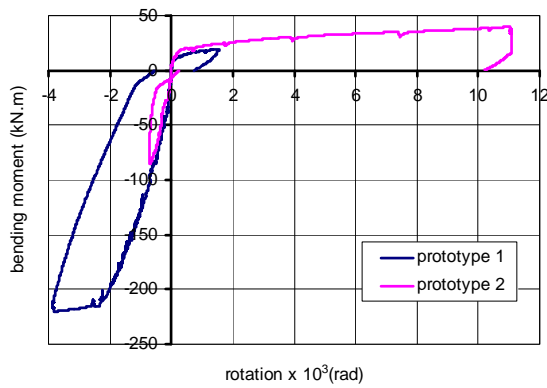

Fig. 16 Envelopes of bending moment versus rotation curves

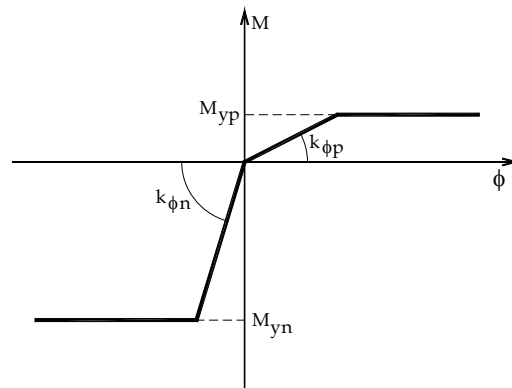

Fig. 17 Bending moment versus rotation curve adopted

Fig. 18 represents a typical 2-story frame structure of 3 spans and the applied loads. It is assumed the following behaviour for the beam-column connection: a) pinned before the connections were effective and b) semi-rigid after the connections were effective. The dead-load (g), which corresponds to the weight of the structure itself, is working in the pinned connections model, while the live-load (q) and the wind load (W) are working in the semi-rigid connections model.

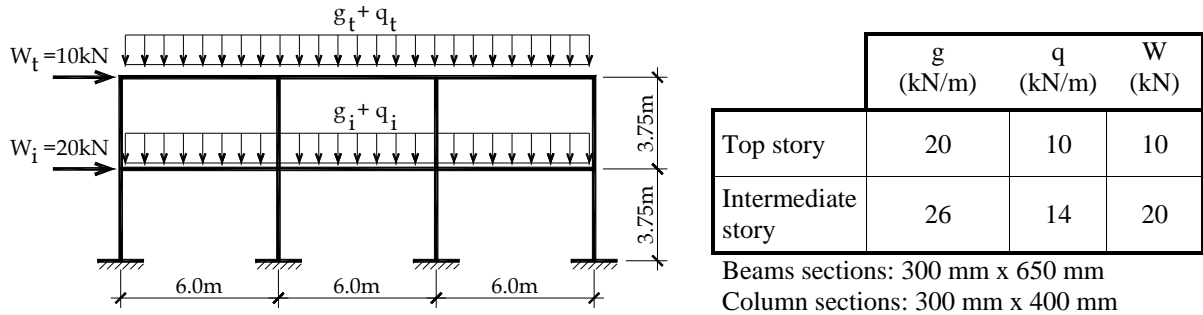

Fig. 18 Analyzed structure and loads used (El Debs et al<sup>8</sup>)

The  $\gamma_z$  coefficient method proposed by Franco & Vasconcelos<sup>9</sup> was chosen for the performed analysis. Concisely, it consists in calculating the  $\gamma_z$  coefficient, which evaluates the deformability of the structure and, multiplied by the horizontal loads, it can also take into account nonlinear effects. The  $\gamma_z$  coefficient is given by:

$$\gamma_z = \frac{1}{1 - \frac{\Delta M_d}{M_{1d}}} \quad (2)$$

where  $M_{1d}$  is the first-order moment at the bottom of the structure due to the lateral loads and  $\Delta M_d$  is the first evaluation of the second-order moments, calculated from the structure deformations due to the first-order moments.

For design purposes, if  $\gamma_z$  is less than 1.1, then there is no need to consider the overall second-order effects.

The displacements of the structure can be obtained using the reduced values of flexural stiffness in order to consider the nonlinear behaviour of the materials. The usual values are  $(EI)_{red} = 0.4EI$  for beams and  $(EI)_{red} = 0.8EI$  for columns, in a framed structure, and  $(EI)_{red} = 0.4EI$  for fixed-end columns (cantilever action) and pinned beams (El Debs 2000<sup>10</sup>). In the absence of data to establish the stiffness reduction for semi-rigid connections, the mean value of 0.60 is considered.

The finite element based software was used to process the calculation. The semi-rigid connections were simulated by spring elements with bi-linear moment x rotation.

In order to analyze the effect of the stiffness of the connections, the following alternatives were considered: a) pinned connections, b) semi-rigid connections with the values presented in table 6 and c) rigid connections (fully restrained connections). The values in table 6 were calculated considering the material properties: a) precast concrete compressive strength of 35 MPa, b) cast-in-place concrete compressive strength of 25 MPa, c) continuity reinforcement and dowel of same diameters and strength of the prototype, and d) elasticity modulus of concrete of 30 GPa, which is approximately the mean value between the precast and the cast-in-situ concrete.

Table 6 Design values of connection rigidity and yielding moments (El Debs et al<sup>6</sup>)

	Internal column		Border column	
	Negative moments	Positive moments	Negative moments	Positive moments
Rigidity (MN/rad)	63.5	5.4	26.4	5.4
Yielding moment (kN.m)	147.5	24.2	70,2	24.2

Table 7 presents the main results obtained for the analyzed situations. Several observations can be made: a) the displacement at the top of the structure for semi-rigid connection is 13.7% of the value considering pinned connection, b) the  $\gamma_z$  coefficient is also significantly reduced, c) the bending moment in the column base for semi-rigid connection is 41.9% of the value considering pinned connection for the load combination G+Q+W and d) for the analyzed parameters, the positive moment at the connection occurs only for load combination G+Q and its value is low.

Table 7 Main results for the alternatives analyzed (El Debs et al<sup>6</sup>)

connections	Loads G + Q + W				Loads G + W			
	a (2) (mm)	$\gamma_z$	$M_b \cdot \gamma_z$ (3) (kN.m)	$M_v \cdot \gamma_z$ (4) (kN.m)	a (2) (mm)	$\gamma_z$	$M_b \cdot \gamma_z$ (3) (kN.m)	$M_v \cdot \gamma_z$ (4) (kN.m)
pinned	29.77	1.19	44.65	0	29.77	1.12	42.02	0
Semi-rigid (1)	4.07	1.03	18.72	-	4.07	1.02	18.54	3.99
Rigid (1)	1.99	1.01	15.27	-	1.99	1.01	15.04	15.00

(1) dead load actuates on pinned connections

(2) a - displacement at the structure top level (average of 4 columns)

(3)  $M_c$  - moment at the column bottom (average of 4 column)

(4)  $M_b$  - positive moment at beam-column connection, (-) means that there is only negative moment.

Based on the presented results, other similar framed structures were simulated, with an increasing number of stories. Vertical and horizontal loads were repeated for the intermediate stories, keeping the same load for the top level. Table 8 shows the results.

Table 8 Results when the number of stories is increased (El Debs et al<sup>6</sup>)

Connection	Load G + Q + W					Load G + W			
	n (1)	a (mm)	$\gamma_z$	$M_b \cdot \gamma_z$ (kN.m)	$M_v \cdot \gamma_z$ (kN.m)	a (mm)	$\gamma_z$	$M_b \cdot \gamma_z$ (kN.m)	$M_v \cdot \gamma_z$ (kN.m)
Pinned	2	29.77	1.19	44.65	0	29.77	1.12	42.02	0
Semi-rigid	2	4.07	1.03	18.73	-	4.07	1.02	18.54	3.99
	3	11.30	1.05	33.94	-	11.30	1.03	33.29	8.52
	4	21.81	1.07	49.29	0.06	21.81	1.05	48.37	13.13
	5	36.30	1.10	66.26	4.75	36.30	1.06	63.85	17.00

(1) n – number of stories

Based on the results in Table 8, two primary conclusions can be drawn. First, it is possible to progress from a 2-story frame with pinned connections to a 4-story one with semi-rigid connections. The displacement at the top would be lower, and the bending moment in the column base would increase slightly, from 44.65 to 49.29 kN.m. Second, even for a 5-story frame, the positive moments at the connection would be lower than the yielding moments, which indicate the possibility of another increase in the height; however, in this case, there would be a large increase in the column base moments.

## CONCLUSIONS AND REMARKS

The main conclusion of these studies can be drawn:

- The mixtures recommended are cement/aggregate ratio of 0,3, cement/water ratio of 0.4, vermiculite in percentage of the total aggregate mass of 5 to 15%, fiber volumetric rate of 2 to 4% and amount of latex in percentage of cement mass of 30%. The representative values for these mixtures would be 20 to 45 MPa for compressive strength and 10 to 15 GPa for modulus of elasticity.
- The bearing pad rigidity obtained for proposed mixtures, measured after the initial accommodation, is about 300 to 400 MPa.
- The CBBP are more rigid than their chloroprene counterparts by a factor of about 3 to 6 for the 10 mm thickness
- The results of the cyclic load tests show that the CBBP rigidity remains constant after a certain stage of plastic deformation, and after large number of cycles. This fact demonstrates the resilient capacity of the CBBP.
- The CBBP can provide some rigidity to the connections which cannot be got with chloroprene one.
- In the example of a typical structure of a multi-story building, it is possible to increase the number of story of the structure from 2 to 4 with lower horizontal displacement at the top and only a small increase of the column base bending moment by using semi-rigid connections.



It must be pointed out that the effects of length changes on the precast component must be taken into account more carefully when CBBP is used.

An alternative to increase the CBBP deformability is using roughness on the surfaces. Studies on this alternative were conducted by Bellucio<sup>11</sup>. The roughness on the pad surfaces improves the capacity of accommodation regarding the imperfections of precast concrete surface.

## ACKNOWLEDGEMENTS

The authors would like to extend their most sincere thanks to Brazilian Research Foundations FAPESP and CNPq for their financial support.

## REFERENCES

1. Precast/Prestressed Concrete Institute, “*PCI Design Handbook: Precast and Prestressed Concrete*”, 7.ed. Chicago: PCI, 2010, (MNL-120-10).
2. Barboza, A.S.R., Soares, A.M.M., and El Debs, M.K., “A new material to be used as bearing pad in precast concrete connections”, *Proceedings of 1st International Conference on Innovation in Architecture, Engineering and Construction*, Eds. Anumba, C.J., Egbu, C., and Thorpe, A., Loughborough, UK, 2001, pp. 81-91.
3. El Debs, M.K., Barboza, A.S.R., and Miotto, A.M.M., “Development of material to be used as bearing pad in precast concrete connections”, *Structural Concrete*, V.4, No.4, Dec. 2003, pp. 185-193.
4. El Debs, M.K., Montedor, L.C., and Hanai, J.B., “Compression tests of cement-composite bearing pads for precast concrete connections”, *Cement and Concrete Composites*, V.28, No. 7, Aug. 2006, pp. 621-629.
5. Siqueira, G.H., “*Bearing pads of cement-base composite for precast concrete*”, Master Degree Dissertation, University of São Paulo at São Carlos, 2007, 169p. (In Portuguese: “Almofada de apoio de compósito de cimento para ligações em concreto pré-moldado”).
6. Sawasaki, F.Y., “*Theoretical and experimental study on beam-column connection made with cement-base bearing pad and bolts for precast concrete structures*”, Master Degree Dissertation, University of São Paulo at São Carlos, 2010, 165p. (In Portuguese: “Estudo Teórico-Experimental de Ligação Viga-Pilar com Almofada de Argamassa e Chumbador para Estruturas de Concreto Pré-Moldado”).
7. El Debs, M.K., El Debs, A. L. H. C., and Miotto, A. M., “Experimental analysis of beam-to-column connection with semi-rigid behavior of precast concrete structures. *Proceedings of Second International Congress of Fédération Internationale du Béton*, Naples, 2006, pp. 1-11.
8. El Debs, M.K., Miotto, A.M., and El Debs, A.L.H.C., “Analysis of a semi-rigid connection for precast concrete”, *Proceedings of the Institution of Civil Engineers: Structures and Buildings*, V.163, No.1, Feb. 2010, pp. 41-51.

9. Franco, M., and Vasconcelos, A.C., “Practical assessment of second order effects in tall buildings”, *Proceedings of the COLLOQUIUM ON THE CEB-FIP MC90*, Rio de Janeiro, 1991, pp. 307-323.
10. El Debs, M.K., “*Precast concrete: Fundamentals and applications*”, School of Engineering of Sao Carlos, University of Sao Paulo, 2000, 441 p. (In Portuguese: Concreto pré-moldado: fundamentos e aplicações).
- 11 Bellucio, E.K., “*Influence of surface roughness and the use of new types of fiber in bearing pads of cement-based material for precast concrete connections*”, Master Degree Dissertation, University of São Paulo at São Carlos, 2010, 106p. (In Portuguese: “Influência da rugosidade superficial e o uso de novos tipos de fibras em almofadas de argamassa para ligações de concreto pré-moldado”).