

# Partial Depth Deck Panel Guidelines

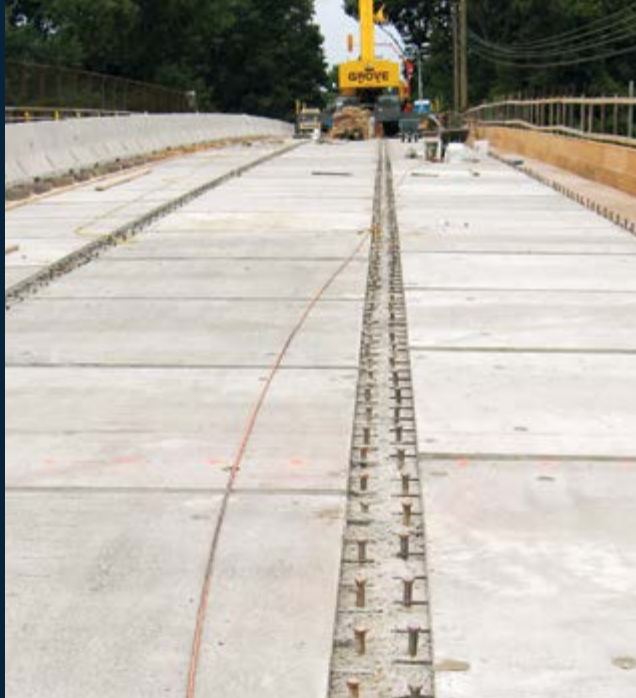

PCI Northeast Bridge  
Technical Committee

*Second Edition*



A Chapter of the  
Precast/Prestressed Concrete Institute

Report Number  
PCINE-17-PDDPG

Date Issued  
February 2017

Report No:  
**PCINE-17-PDDPG**

Copyright © 2017

**By Precast/Prestressed Concrete Institute Northeast**

Second Edition, first printing, 2017

All rights reserved. This guide or any part thereof may not be reproduced in any form without the written permission of the Precast/Prestressed Concrete Institute Northeast.

Printed in the U.S.A

*The details shown are guidelines and should not be considered standards. Information contained in this work has been obtained from sources believed to be reliable. PCI Northeast or its memberships shall not be responsible for any errors, omissions, or damages arising out of this information. PCI Northeast has published this work with the understanding that PCI Northeast is supplying information only. PCI Northeast is not rendering engineering or other professional services through this guideline. If such services are required, please seek an appropriate professional.*

## FORWARD

This guideline has been developed for the purposes of promoting a greater degree of uniformity among owners, engineers, and industry of the Northeast, with respect to planning, designing, fabricating, and constructing bridges using partial depth deck panels.

The PCI Northeast Tech Committee would like to thank Jason Tremblay from New Hampshire Department of Transportation for updating the Partial Depth Deck Panel Guideline. The first edition was developed by Peter Stamnas from New Hampshire Department of Transportation in 2001. The second edition was reviewed and approved by the PCI Northeast Bridge Technical committee.

**Rita Seraderian**, PCI Northeast Executive Director (PCINE); Belmont, MA

**Michael P. Culmo**, CME Associates, Inc., East Hartford, CT

**Jason Tremblay**, New Hampshire DOT, Concord, NH

**David Scott**, New Hampshire DOT, Concord, NH

**Pete Stamnas**, New Hampshire DOT, Concord, NH

**Eric Calderwood**, Principal, Calderwood Engineering, Richmond, ME

**Ed Barwicki**, Lin Associates; Boston, MA

**Darren Conboy**, Jacobs Engineering, Boston, MA

**John Byatt**, CLD Engineers, Manchester, NH

**Scott Harrigan**, Fort Miller Group, Schuylerville, NY

**Bryan Reed**, Connecticut DOT, Newington, CT

**Maura Sullivan**, Massachusetts DOT, Boston, MA

**Alex Bardow**, Massachusetts DOT, Boston, MA

**Edmund Newton**, Massachusetts DOT, Boston, MA

**Michael Merlis**, Massachusetts DOT, Boston, MA

**Troy Jenkins**, Northeast Prestressed Products, LLC, Cressona, PA

**Art Palmer**, Dailey Precast, Shaftsbury, VT

**Joe Carrara**, J. P. Carrara & Sons, Middlebury, VT

**Ben Cota**, J. P. Carrara & Sons; Middlebury, VT

**Brian Reeves**, Maine DOT; Augusta, ME

**Duane Carpenter**, New York State DOT, Albany, NY

**Michael Twiss**, New York State DOT, Albany, NY

**Mike Savella**, Rhode Island DOT, Providence, RI

**Chris Fowler**, Oldcastle Precast, Rehoboth, MA

**Rob Young**, Vermont Agency of Transportation, Montpelier, VT

**Terry Seymour**, Unistress Corp., Pittsfield, MA

# Contents

<b>Forward</b>	<b>i</b>
----------------	----------

<b>Section 1: Guidelines For Design &amp; Detailing Of Precast Partial Depth Deck Panels</b>	<b>3</b>
--	----------

<b>1.1 Design and Detail Requirements</b>	<b>3</b>
<b>1.2 Temporary Support System</b>	<b>3</b>
<b>1.3 Haunch Height</b>	<b>3</b>
<b>1.4 Skewed Ends</b>	<b>3</b>
<b>Details</b>	
Deck Panel Detail	4
Haunch Detail	5
Bulb-Tee Top Flange Detail	6

<b>Section 2: Specification Sections For Precast Partial Depth Deck Panels</b>	<b>7</b>
--	----------

<b>2.1 Materials</b>	<b>7</b>
2.1.1 Temporary Supports/Grout Dams	7
2.1.2 Grout Bed	7
<b>2.2 Construction</b>	<b>7</b>
2.2.1 Dimensional Tolerances	7
2.2.2 Non-Conformance of Deck Elements	8
2.2.3 Installation	8

## Section 1: Guidelines For Design & Detailing Of Precast Partial Depth Deck Panels

Precast prestressed concrete deck panels used as permanent forms spanning between girders should be designed to act composite with the cast-in-place portion of the deck slab.

### 1.1 Design and Detail Requirements

1. The concrete compressive strength at release  $f'_{ci}$  should be a **minimum** of 4 ksi. The 28-day concrete compressive strength should be 6 ksi.
2. Tension in the precompressed tensile zone under final service conditions after all losses have occurred should be  $\leq 0.19\sqrt{f'_c}$ . Compression in the panel at release should be  $\leq 0.750$  +/- ksi.
3. Prestressing strands shall be 3/8" diameter and should extend 4 in. minimum outside the panel ends and shall be centered vertically in the panel.
4. Panel length should be set to provide a **minimum** grout bed width of 2.25 in. to account for width of panel and sweep tolerances. This requires a minimum of 3.75 in. from the edge of panel to the edge of steel girder flange and 4.25 in. to the edge of a bulb-tee flange, assuming a 1.5 in. minimum grout dam width.
5. The minimum thickness of the cast-in-place portion of the slab should be 4.5 in.
6. The minimum thickness of the panel shall be 3.5 in. The top surface shall be broom roughened to an amplitude of approximately 0.06 in. parallel to strands.
7. Design shall be standard AASHTO design of composite sections.

### 1.2 Temporary Support System

**Two Step System:** After setting deck panels, a grout bed is placed in the girder haunch area and allowed to cure prior to placing the remainder of the deck.

1. Temporary supports for precast deck panels shall consist of continuous, high-density, expanded polystyrene strips (grout dam) with a minimum compressive strength of 55 psi. If leveling screws are used a 1.7 pound per cubic foot polyethylene foam seal shall be used as a grout dam. An approved adhesive should be specified to affix the grout dam to the girder and the deck panel. For narrow flanges, steel angles and shim stacks should be considered to meet minimum grout bed width.
2. Temporary bracing between the ends of panels shall be installed as required to prevent transverse panel movement that could lead to loss of bearing on the leveling screws. With greater cross slopes, leveling screws should be checked for bending.



3. Deck panels are required to be grouted in place prior to placement of the cast-in-place concrete deck. The grout bed should extend for the full width of the girder flange completely filling the area between the grout dams. The top of the grout bed should be 1 in. clear below the strand extensions.
4. If leveling screws are used they shall be completely removed after the grouting operation and prior to deck placement.

### 1.3 Haunch Height

The haunch height should take into account the following factors:

1. A **minimum** blocking distance, 1 in. min allowance for cross-slope, camber and camber tolerance.
2. The flange bolts for field splices of steel girders may interfere with precast concrete deck panels. Provide a haunch depth that accommodates the added thickness of the field splice. Modifying panel thickness to avoid conflict with field splices shall not be allowed. Forming the deck in the area of conflict and placing cast-in-place concrete is an acceptable method.

### 1.4 Skewed Ends

The use of partial depth prestressed deck panels at skewed ends is not recommended. If used, the designer should account for the skewed support of the panel and its effect on the reinforcing. Shielding of the strand in the acute end of the panel may be required to control potential cracking. Additional mild steel placed adjacent to shielded strands or along the skew may be required to meet the design capacity of the deck. The use of non-prestressed skewed end panels can also be considered. The design should account for the support conditions of all edges of the panel.

# Partial Depth Deck Panel Guidelines

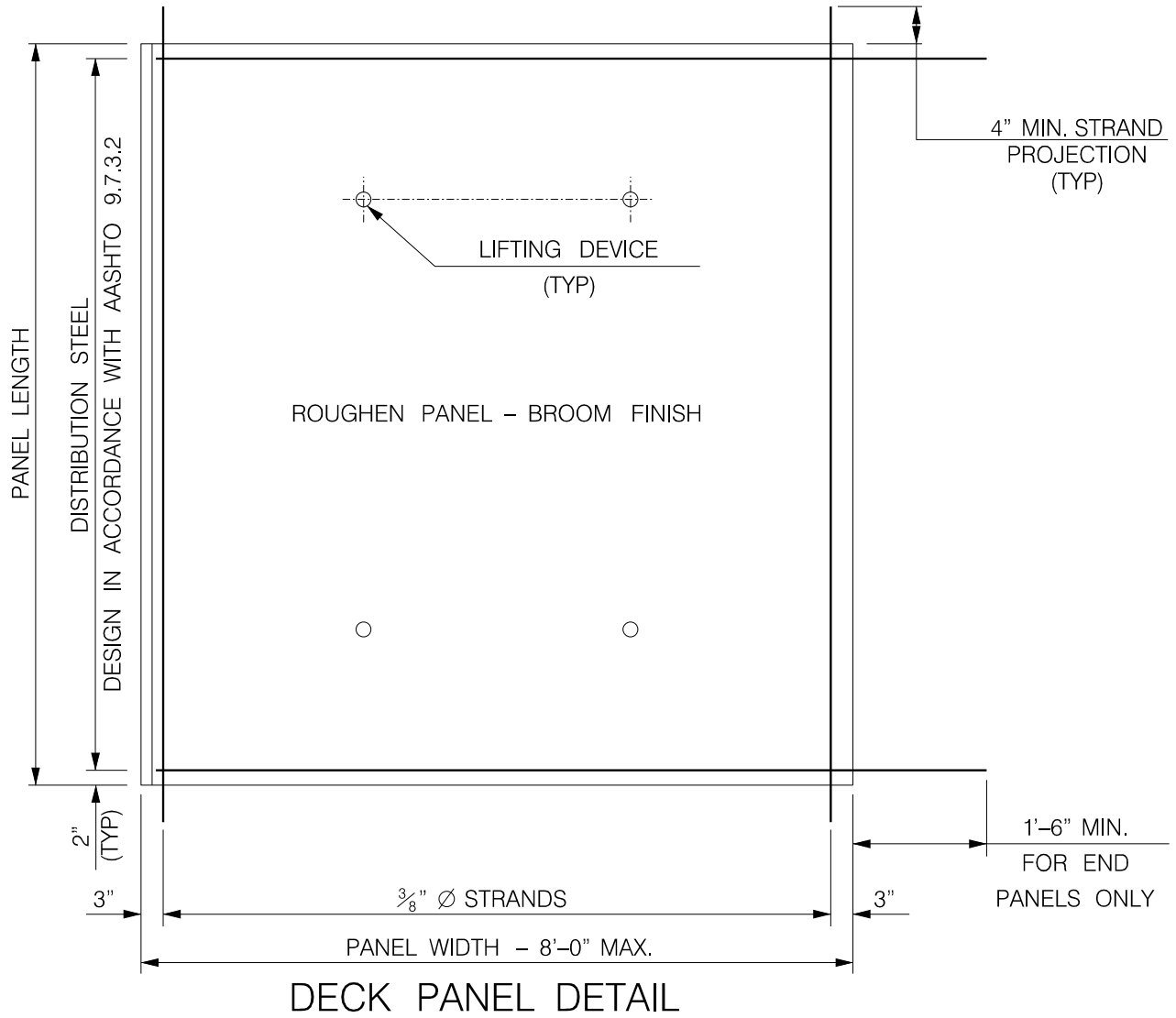
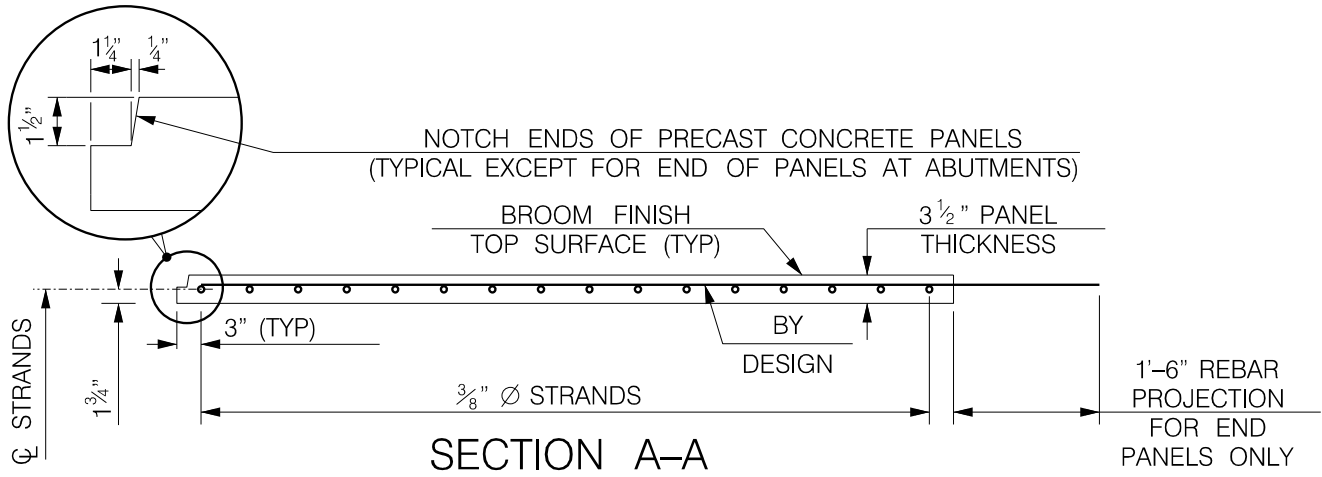

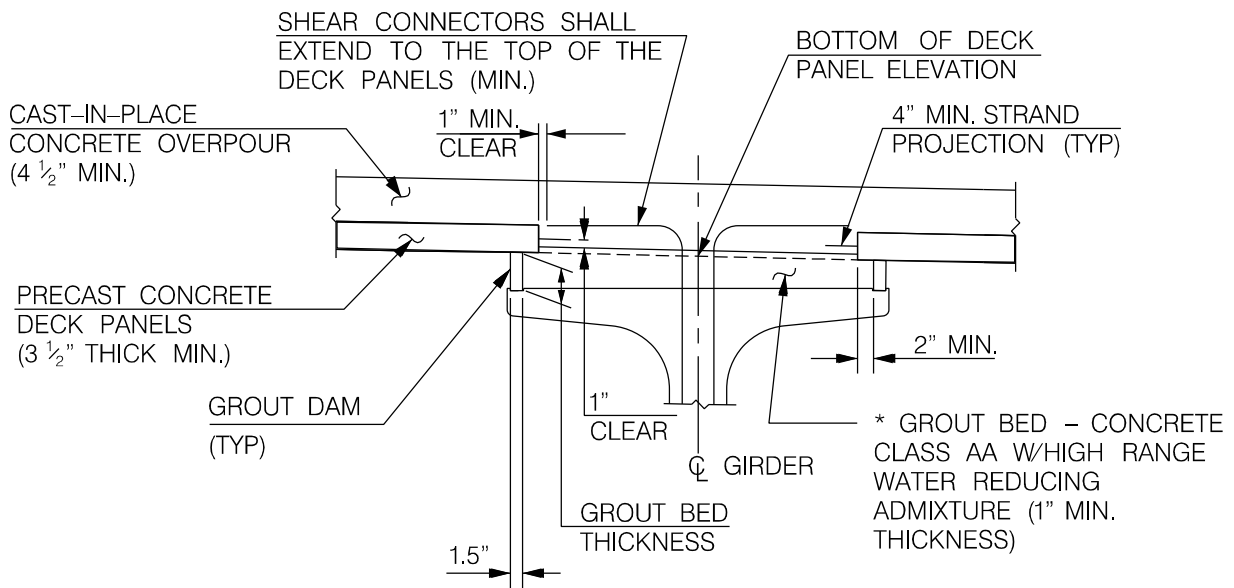

### BULB-TEE GIRDER HAUNCH DETAIL

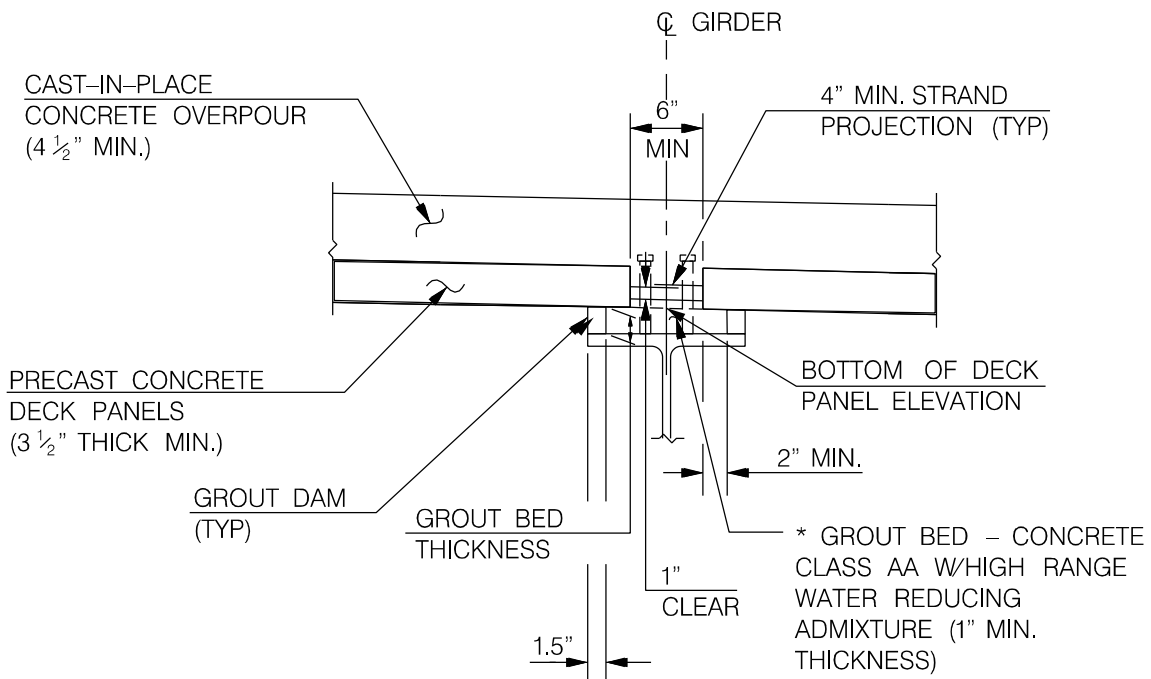

### STEEL GIRDER HAUNCH DETAIL

\* ENSURE GROUT FLOWS UNDER PANEL FOR COMPLETE BEARING

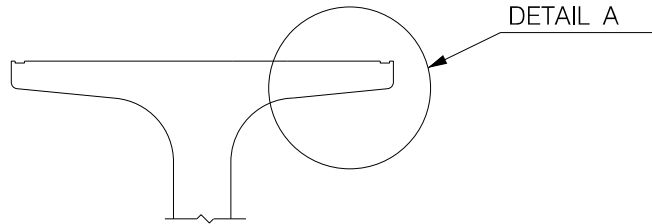

BULB-TEE TOP FLANGE DETAIL

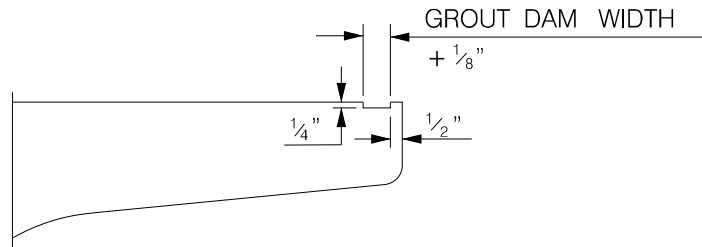

DETAIL A



## Section 2: Specification Sections For Precast Partial Depth Deck Panels

The following information is offered as a supplement to existing concrete and prestressed concrete specifications.

### 2.1 Materials

#### 2.1.1 Temporary Supports/Grout Dams

Temporary supports/grout dams for precast deck panels shall consist of continuous, high-density, expanded polystyrene strips (grout dam) with a minimum compressive strength of 55 psi. If leveling screws are used, a 1.7 pound per cubic foot polyethylene foam seal shall be used as a grout dam. An approved adhesive should be specified to affix the grout dam to the girder and the deck panel.



#### 2.1.2 Grout Bed

This work shall consist of furnishing and placing a grout bed using high density low slump concrete, including high range water reducing admixture, beneath the ends of prestressed concrete deck panels and on the girder top flange as shown on the contract plans and conforming to the following material requirements:

- Concrete

Concrete Class	Strength ksi	Cement lbs	Maximum W/C	Percent Entrained Air
AA	4	882.5	0.38	7 to 9

- Portland Cement shall conform to AASHTO M 85 Type II.
- Coarse aggregate for Concrete Class AA, including high range water reducing admixture, shall meet the following gradation:

Sieve Size	1/2"	3/8"	No. 4	No. 8	No. 16	No. 50
% Passing	100	90-100	20-55	5-30	0-10	0-5

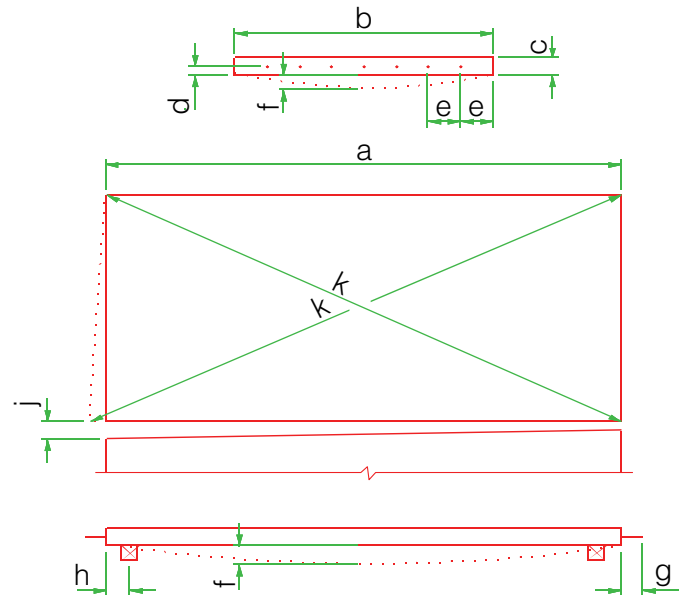

### 2.2 Construction

#### 2.2.1 Dimensional Tolerances

Panels shall be manufactured in conformity with the following tolerances:

- a, Length of panel . . . . . ±1/4 inches
- b, Width of panel . . . . . ±1/4 inches
- c, Depth of panel . . . . . -1/8, +1/4 inches
- d, Vertical position of strand group . . . . . -1/8, +0 inches  
(Measured from bottom of panel)
- d, Vertical position of individual strands . . . . . ±1/8 inches
- e, Horizontal strand position . . . . . ±1/4 inches
- f, Bowing . . . . . ±1/8 inches
- g, Strand projection . . . . . ±1/2 inches
- h, Dunnage location . . . . . ±6 inches
- i, Sweep . . . . . ±1/8 inches
- j, Horizontal alignment . . . . . 1/4 inches  
(Deviation from straight line parallel to centerline of panel)
- k, Squareness . . . . . 1/2 inch (max.)  
(Difference in diagonals)
- Warping . . . . . 1/16 inch per foot  
of distance from  
nearest adjacent  
corner

# Partial Depth Deck Panel Guidelines

## 2.2.2 Non-Conformance of Deck Elements

Plant cast prestressed bridge products are produced in PCI certified plants. Products are manufactured in accordance with the *Manual for Quality Control for Plants and Production of Structural Precast Concrete Products* Fourth Edition MNL-116-99.

As with any manufacturing process defects can occur in precast prestressed concrete deck products. These defects fall into one of three categories:

- Those that can be accepted without repair
- Those that can be repaired
- Those that must be rejected

The PCI Northeast "*Bridge Member Repair Guideline* (PCINER-01-BMRG)" has been prepared to be a resource to guide owners, designers and fabricators in reaching informed and considered decisions on which option is appropriate. TS #11 TROUBLE SHOOTING CRACKS AND HONEYCOMBING IN PRECAST, PARTIAL DEPTH DECK PANELS describes and evaluates the non-conformance. The guideline can be downloaded at [www.pcine.org](http://www.pcine.org) under bridge resources.

## 2.2.3 Installation

The panels shall be installed as shown on the plans. The temporary supports shall be attached to the top flange of the girder with an approved adhesive in accordance with the Manufacturer's recommendations. The temporary supports shall be cut in the field to the required height after the blocking depth has been determined.

Multiple panels shall not be stacked on a panel after it has been placed on the temporary supports.

Panels shall not be used to support heavy loads until the full deck concrete is cast and cured. Construction loads on individual panels shall be uniformly applied and shall not exceed an average loading of approximately 40 pounds per square foot.

After the panels have been placed on the temporary supports, the area under the ends of the panels and on the girder flanges up to the bottom of the panels shall be completely filled with Concrete Class AA, Including High Range Water Reducing Admixture as shown on the plans.



This concrete shall cure a minimum of three (3) days prior to placing the concrete deck. If leveling screws are used, they shall be completely removed and the holes filled with grout **prior** to the placement of deck concrete.

Adequate precautions shall be taken to protect freshly placed concrete from sudden or unexpected rain. The Owner may order removal of any material damaged by rainfall.

The grout bed shall not be placed when air or deck temperature is below 50°F. It may be placed when these temperatures are a minimum of 50°F and rising air temperature is predicted.

Prior to placement of the deck concrete, laitance or other contaminants that would interfere with full bond to the panels, shall be removed by an approved method.





A Chapter of the  
Precast/Prestressed Concrete Institute

116 Radcliffe Road • Belmont, MA 02478  
Phone: 888.700.5670 • Fax: 617.489.5810