

PCI DESIGN HANDBOOK

PRECAST AND PRESTRESSED CONCRETE

8TH EDITION ERRATA

PCI Design Handbook

Precast and Prestressed Concrete,

Eighth Edition Errata

In 2017, the Precast/Prestressed Concrete Institute published the eighth edition of the *PCI Design Handbook: Precast and Prestressed Concrete* (MNL-120-17). The committee devoted significant effort to providing an accurate document; however, some errata have been discovered. The errata published herein are intended to supplement, revise, or clarify the information provided in the handbook. PCI suggests you mark the changes in your copy so that your handbook is as accurate as possible. New errata since the previous version published in September 2019 are marked with a vertical bar in the margin.

As this edition of the handbook is used, additional errata may be discovered. You are urged to notify PCI of any potential errata for committee review. You are also encouraged to send any questions or comments to PCI regarding the material in the handbook and suggested improvements or clarifications. Please direct your comments to PCI at IHBerrata@pci.org.



Chapter 1

Page 1–3, left column, second paragraph, line 6: Delete “, Section 14.1 of this handbook,”. [*Committee note: The PCI Standard Design Practice for the Building Code Requirements for Structural Concrete (ACI 318-14) and Commentary (ACI 318R-14)*¹ was not completed for publication with the eighth edition handbook. When it is completed, the PCI Standard Design Practice will be published in the PCI Journal and on the PCI website.]

Page 1–9, left column, first paragraph, line 4: Replace “Section 14.4.4.3” with “Section 14.1.4”.

Page 1–26, left column, second paragraph, line 9: Replace “Section 14.4” with “Section 14.1.4”.

Chapter 2

Page 2–25, below “Chapter 8”, item 11: Add “ e = distance from center of gravity of component to top picking point of the rolling block (see Fig. 8.6.2)”.

Page 2–30, below “Appendix B—Design for Structural Integrity and Disproportionate Collapse”: Replace “See end of Appendix for notation used.” with “Not included.”

Page 2–30, below “Appendix C—Precast Concrete Diaphragm Design in Accordance with Alternative Provisions of ASCE 7-16”: Replace “See end of Appendix for notation used.” with “Not included.”

Chapter 4

Page 4–5, Figure 4.1.1 caption: Replace “reference 2” with “reference 4”.

Page 4–27, Example 4.5.7.1, under “Solution,” after “Determine center of rigidity:”: Replace calculation result of “103.9 ft” with “130.9 ft”.

Page 4–95, Design Aid 4.10.23: Replace “Reference 19” with “Reference 14”.

Page 4–96, Design Aid 4.10.24, in parenthesis after “Values of k_b ”: Replace “Design Aid 4.10.25” with “Design Aid 4.10.28”.

Chapter 5

Page 5–46, Figure 5.3.1: Insert “(if using Eq. 5-24)” after “ $5.0\lambda\sqrt{f'_c}b_wd$ ”. Delete “or Eq. 5-27” after “ V_{ci} (Eq. 5-25)”.

Page 5–48, Example 5.3.1.1, under “Given”: Replace “ $f_y = 65,000$ psi” with “ $f_y = 60,000$ psi for plain WWR.” [*Committee note: Limit is per ACI 318-14*¹ Table 20.2.2.4a for plain WWR.] Replace the results at the bottom of the page with the following:

From Eq. 5-29:

$$A_v = 0.75\sqrt{f'_c}\frac{b_ws}{f_{yt}} = \frac{0.75(\sqrt{5000})(8)(12)}{65,000-60,000} = 0.079-0.084 \text{ in.}^2/\text{ft} \text{ or } 0.039-0.042 \text{ in.}^2/\text{ft} \text{ per layer of WWR}$$

But should not be less than Eq. 5-30:

$$A_v = 50b_w\frac{s}{f_{yt}} = \frac{50(8)(12)}{65,000-60,000} = 0.074-0.080 \text{ in.}^2/\text{ft} \text{ or } 0.037-0.040 \text{ in.}^2/\text{ft} \text{ per layer of WWR}$$

Page 5–49, Example 5.3.1.1, lines 1 and 4: Replace “0.039 in.²/ft” with “0.042 in.²/ft”.

Page 5–52, Example 5.3.3.1, under “Shear reinforcement”: Replace “ $f_{yt} = 65,000$ psi” with “ $f_{yt} = 60,000$ psi for plain WWR.” [Committee note: Limit is per ACI 318-14¹ Table 20.2.2.4a for plain WWR.] Under “Solution”: Revise calculations as follows:

From Eq. 5-29:

$$A_{v,min} = 0.75 \sqrt{f_c} \frac{b_w s}{f_{yt}}$$

$$A_{v,min} = 0.058 = 0.75 \sqrt{5000} \frac{(9.5)s}{65,000 \cdot 60,000}$$

Solving for s:

$$s = 7.5 \text{ 6.9 in.}$$

From Eq. 5-30:

$$A_{v,min} = 50 \frac{b_w s}{f_{yt}}$$

$$A_{v,min} = 0.058 = 50 \frac{(9.5)s}{60,000}$$

Solving for s:

$$s = 7.3 \text{ in.}$$

From Eq. 5-31:

$$A_{v,min} = \frac{A_{ps} f_{pu} s}{80 f_{yt} d} \sqrt{\frac{d}{b_w}}$$

$$A_{v,min} = 0.058 = \frac{(1.53)(270)s}{(80)(65,600)(21.6)} \sqrt{\frac{21.6}{9.5}}$$

Solving for s:

$$s = 10.5 \text{ 9.7 in.}$$

Use W2.9 wires at a maximum spacing $s = 10.5 \text{ 9.7 in.}$ (rounded to 9.5 in.)

Page 5–52, Example 5.3.3.2, under “Solution”: Replace the results with the following. [Committee note: Limit is per ACI 318-14¹ Table 20.2.2.4a for plain WWR.]

From Eq. 5-32: with $s = 12$ in.

$$A_v = \frac{\left[\left(\frac{V_u}{\phi} \right) - V_c \right] s}{f_{yt} d}$$

$$A_v = \frac{(10)(12)}{(65,600)(21.6)} = 0.086 \text{ 0.093 in.}^2/\text{ft}$$

Use two rows (one row per stem) of WWR W2.9, vertical wire spacing = 6 in.

$$A_{v,prov.} = (2)(2)(0.029) = 0.116 \text{ in.}^2/\text{ft}$$

Shear strength provided by reinforcement:

$$V_{s,prov.} = \frac{(0.116)(65,600)(21.6)}{12} = 13.6 \text{ 12.5 kip } \text{ OK}$$

Page 5–55, Example 5.3.4.1, below “Check maximum by Eq. 5-37b”: Replace “Therefore, design by Eq. 5-31a” with “Therefore, design by Eq. 5-37a”.

Page 5–63, Example 5.4.1.2, below step 2, after “Determine f_{pc} ”: Replace “Design Aid 15.3.4” with “Design Aid 15.2.4”.

Page 5–75, Example 5.5.2.1, after “Determine ℓ_d ”: Replace “Design Aid 15.3.4” with “Design Aid 15.3.2”.

Page 5–75, right column, second paragraph: Revise as follows:

Page 5–75, right column, item 1 in second numbered list: Replace “Eq. 5-64” with “Eq. 5-63”.

“These criteria indicate that only short, shallow recesses having the minimum amount of main reinforcement or more extending into the nib (the concrete section above the dap) do not require dap reinforcement. Experience and *Development of Rational Design Methodologies for Dapped Ends of Prestressed Concrete Thin-Stemmed Members* have shown that, for short, shallow recesses, the hanger reinforcement A_{sh} and A'_{sh} is not necessary. However, in these cases, it is recommended that confinement reinforcement A_v and flexural reinforcement $A_{vf} + A_n$, in accordance with Section 5.5.2, be provided. See Section 5.5.3.7 for design and detailing requirements for notches not considered to be dapped ends.”

Page 5–76, Figure 5.5.3, top figure: Replace figure with the following to remove “Center of gravity of flexural reinforcement” and associated leader line at bottom of figure and to add “Critical, minimize” and associated dimension lines:

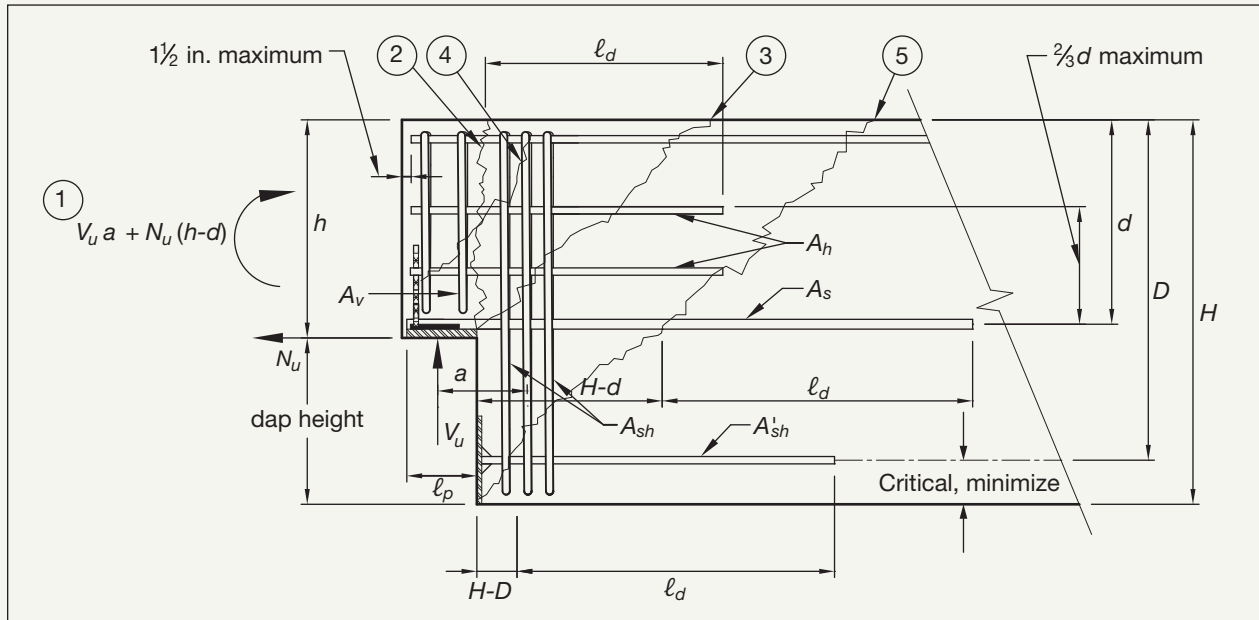

Page 5–77, Figure 5.5.4 (b): Replace figure with the following to delete the dowel bar and vertical plate at the bearing angle:



Page 5-77, Figure 5.5.4 (c): Replace figure with the following to delete the C-shaped A_h reinforcement:

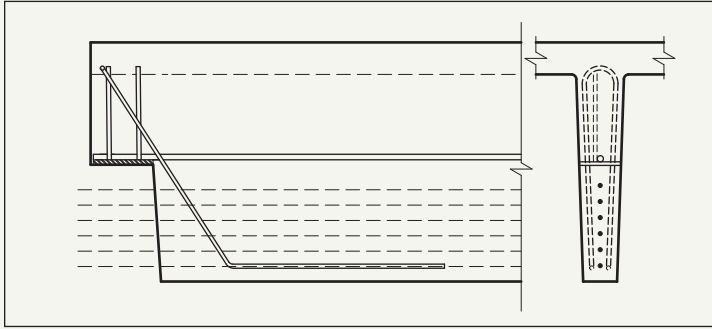

Page 5-78, Figure 5.5.5: Replace figures with the following. Changes include adding the vertical crack 2 on the top and crack numbers on the bottom figure, revising the length of the A_s on the bottom figure, and deleting the $2h$ dimension line and A_h on the section:

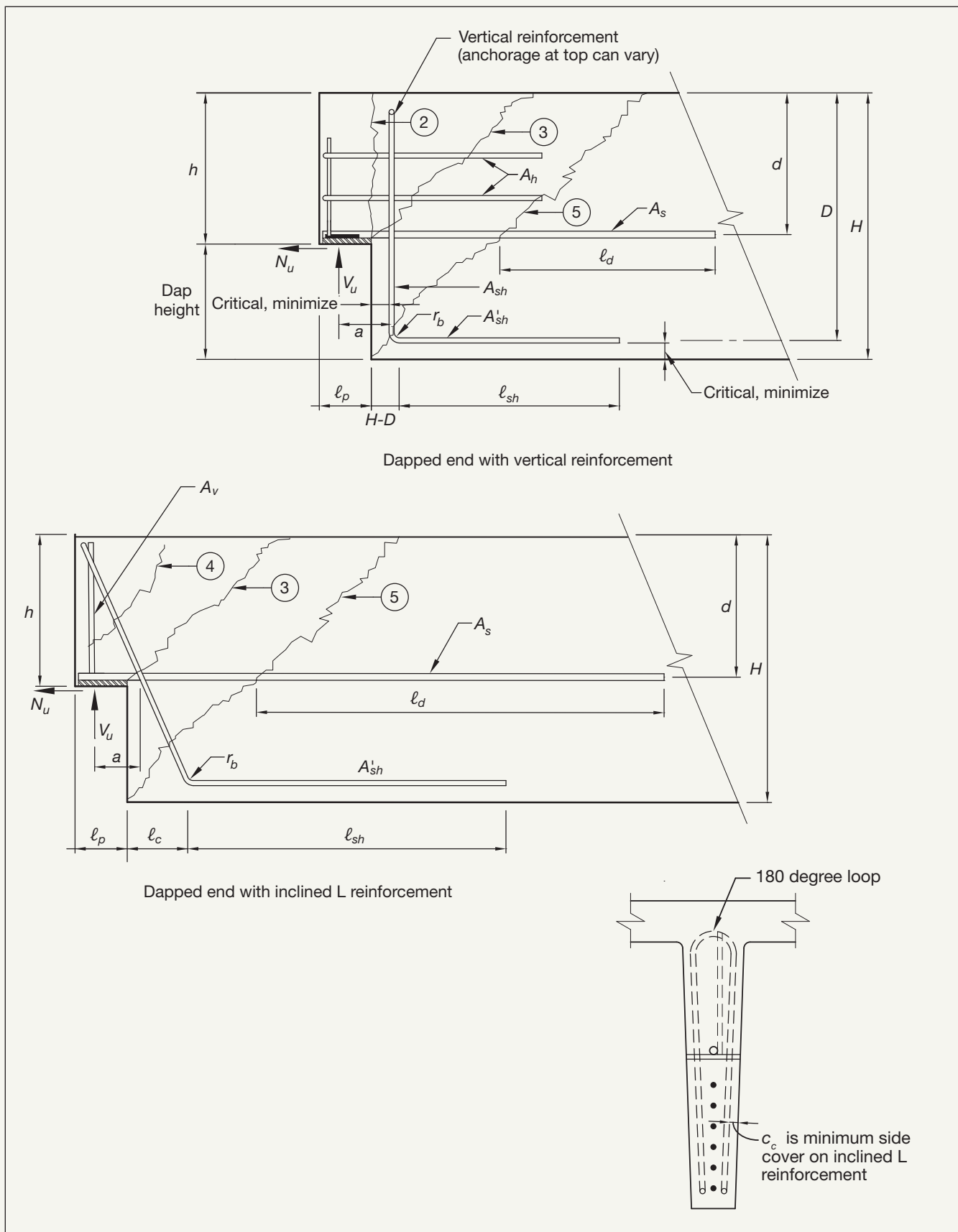

Page 5–78, Figure 5.5.5: Add the following note to figure: “Note: See Eq. 5-73, 5-74, and 5-75 for limits on the shear strength for a distance of $2H$ beyond the dap.”

Page 5–79, left column, second bullet below step 5: Insert “For thin-stemmed components,” before “ A'_{sh} should extend a distance that is the greater...”.

Page 5–79, left column, third paragraph: Replace “(as calculated by Eq. 5-63 or 5-64)” with “(as calculated by Eq. 5-64)”.

Page 5–80, right column, after last paragraph: Insert new section as follows:

“5.5.3.7 Notches

Design and detailing requirements for dapped ends (Sections 5.5.3.1 through 5.5.3.6) do not apply to notches. Notches are defined as shallow recesses where the depth of the recess is less than the lesser of $0.2H$ and 8 in.

The minimum amount of horizontal reinforcement in a notch should be the greatest of:

$$A_s = \frac{(V_u + N_u)}{(\phi f_y)}$$

$$A_s = \frac{3\sqrt{f'_c} b_w d}{f_y}$$

$$A_s = \frac{200 b_w d}{f_y}$$

where

b_w = average web width above the notch

d = depth to A_s as defined for a dap

The amount of required horizontal reinforcement in a notch can be reduced by considering the contribution of the partially developed prestressed reinforcement across the potential 45-degree crack extending upward from the end of the bearing.

Horizontal reinforcement should be anchored at the end of the component by welding to cross bars, plates, or angles, extended into the span the greater of $1.5\ell_t$ or $1.5\ell_d$, and configured such that $\frac{c_c}{d_b}$ is at least 1.5.

For thin-stemmed components, for a distance $2H$ beyond the notch, the concrete contribution to shear strength should be limited to:

$$V_c = 2\lambda\sqrt{f'_c} b_w d$$

where

b_w = average web width above the notch

d = depth to A_s as defined for a dap”

Page 5–81, Example 5.5.3.1, below “step 3. Diagonal tension at reentrant corner”: Replace “ A_s ” with “ A_{sh} ” after “Use six no. 4 closed stirrups;”. Replace “ A_s ” with “ A'_{sh} ” after “Use five no. 6;”. Add “**Consider OK**” after “2.20 in.”.

Page 5–84, Example 5.5.3.2, step 2, line 3: Replace “Eq. 5-58, 5-59, and 5-60” with “Eq. 5-35, 5-64, and 5-65”.

Page 5–84, Example 5.5.3.2, step 2, line 9: Revise calculation as follows:

$$A_h = 0.5(A_s - A_n) = 0.5(0.325 - 0.196 - 0.078) = 0.124 - 0.059 \text{ in.}^2$$

Page 5–85, Example 5.5.3.2, below “Check $A_{v,min}$ per ACI 318-14 Section 9.6.3.3”: Revise calculations as follows:

$$\frac{A_{v,min}}{s} = 50 \frac{b_w}{f_y} = (50) \frac{6.25}{65,000 - 60,000} = 0.0048 - 0.0052 \text{ in.}^2/\text{in.} = 0.058 - 0.0625 \text{ in.}^2/\text{ft}$$

$$\frac{A_{v,min}}{s} = 0.75 \sqrt{f_c} \frac{b_w}{f_y} = (0.75) \sqrt{6000} \frac{6.25}{65,000 - 60,000} = 0.0056 - 0.0061 \text{ in.}^2/\text{in.} = 0.067 - 0.0726 \text{ in.}^2/\text{ft}$$

Using WWR ($f_y = 65$ 60 ksi):

$$\frac{A_v}{s} \geq \frac{V_s}{f_y d_p} = \frac{12.8}{65 - 60(24)} = 0.0082 - 0.0089 \text{ in.}^2/\text{in.} = 0.098 - 0.1067 \text{ in.}^2/\text{ft}$$

Therefore, this is the minimum required

From Design Aid 15.4.3, two layers of WWR 12 × 6 – W1.4 × W2.5 W2.9

$$A_s = 2(0.05 - 0.058) = 0.10 - 0.116 \text{ in.}^2/\text{ft} \quad \mathbf{OK}$$

Page 5–87, right column, Eq. 5-80: Insert λ for lightweight concrete into equation between ϕ and 12.

Page 5–89, left column, Eq. 5-82: Delete ϕ from denominator.

Page 5–90, Example 5.6.1, below “Near midspan (location of third stem)”: Delete “= 12.5 ft” after “ $d_c = 149.5$ in.”

Page 5–90, Example 5.6.1, below “Additional information”: Replace “ $d = 78$ in.” with “ $d_p = 78$ in.” Replace “ $d_t = 10.25$ in.” with “ $d_t = 9.75$ in.” [Committee note: The condition on page 5–87 sets a minimum limit for $b_t = 4$ in. The value used is below that limit; however, there would be numerous corresponding changes throughout the example. Committee decided to leave as is.]

Page 5–91, Example 5.6.1, step 1 of “Check at the end of the beam”, below “to calculate V_s ”: Replace “ d ” with “ d_p ”.

Page 5–92, Example 5.6.1, step 1 of “Check near midspan”, below “to calculate V_s ”: Replace “ d ” with “ d_p ”.

Page 5–93, Example 5.6.1, below “Check longitudinal bending of the ledge”: Revise calculation as follows:

$$A_t = 200 \ell_p \left(\frac{d_t}{f_y} \right) = 200(8) \left(\frac{10.25 - 9.75}{60,000} \right) = 0.273 - 0.260 \text{ in.}^2$$

Page 5–93, Example 5.6.1, below “Determine reinforcement for out-of-plane bending near beam end (Section 5.4.3)”: Replace “From Eq. 5-55” with “From Eq. 5-60”.

Page 5–99, left column, second paragraph under “5.7.1 Cantilever Beam Design Method”: Replace “ $(\frac{2}{3})(A_{vf} + A_n)$ ” with “ $(\frac{2}{3}A_{vf} + A_n)$ ”.

Page 5-99, Figure 5.7.1: Replace figure with the following. Change revises minimum $d/2$ dimension at face of corbel to extend from bearing surface of corbel rather than from centroid of primary reinforcement in agreement with ACI 318-14 Section 16.5.2.2 and Figure R16.5.1a. Change also revises Note 1 to replace “Design Aid 15.4.4” with “Design Aid 15.3.2”.

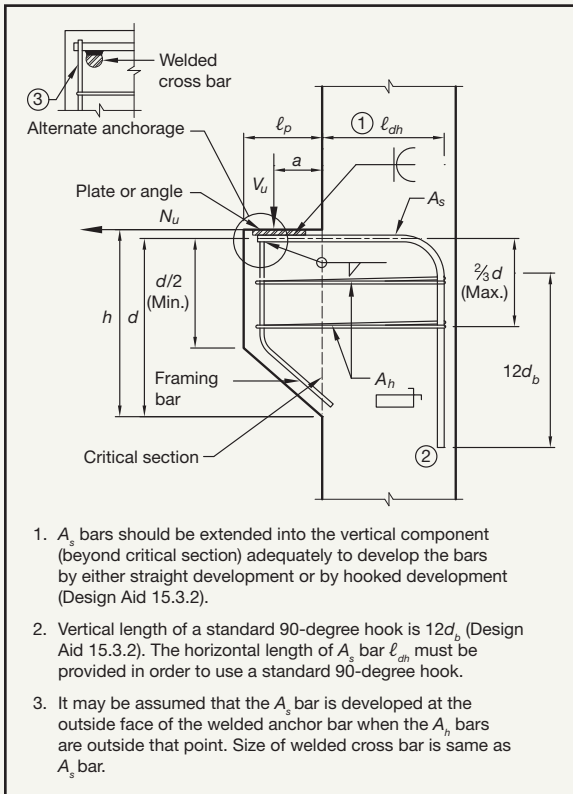

Page 5-101, Figure 5.7.2: Replace figure with the following. Change replaces $h/2$ dimension at the face of the corbel with $d/2$.

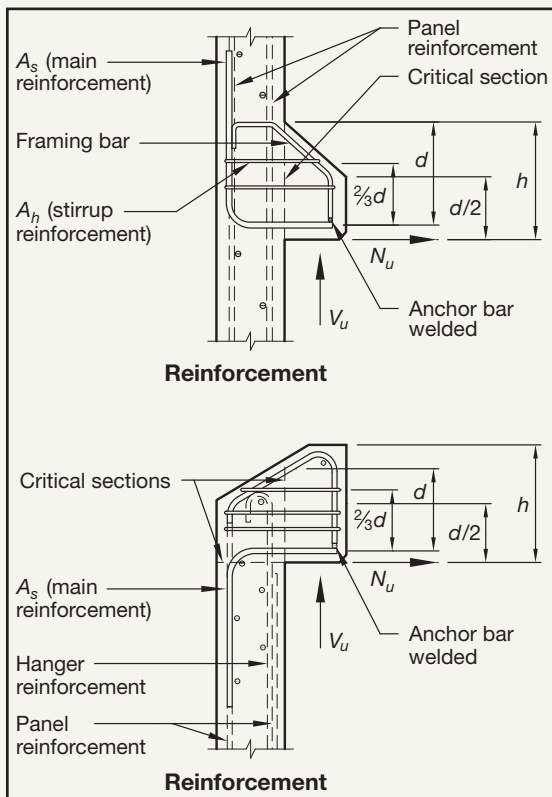

Page 5–109, right column, first paragraph under “5.9.1 Initial Camber”: Replace Design Aid 5.15.1” with “Design Aid 5.16.1”.

Page 5–110, Example 5.9.1.1, under “*Solution*”: Replace “Design Aid 5.15.1” with “Design Aid 5.16.1”.

Page 5–117, Example 5.9.4.1, footnote under the table: Replace “From Example 5.8.1.1” with “From Example 5.9.1.1”.

Page 5–118, left column, fourth paragraph, line 6: Replace “Design Aid 5.15.2” with “Design Aid 5.16.2”.

Page 5–118, left column, sixth paragraph, line 5: Replace “Design Aid 5.15.2” with “Design Aid 5.16.2”.

Page 5–118, right column, first paragraph, line 1: Replace “Eq. 5-102” with “Eq. 5-112”.

Page 5–118, right column, first paragraph, lines 1 and 2: Replace “Design Aid 5.15.2” with “Design Aid 5.16.2”.

Page 5–119, Example 5.9.5.1, under “*Solution*”: Replace “From Eq. 5-110” with “From Eq. 5-112”.

Page 5–119, Example 5.9.5.1: Replace “Design Aid 5.15.2” with “Design Aid 5.16.2” in three places.

Page 5–120, Example 5.9.5.2, under “*Solution*”: Replace “Design Aid 5.15.2” with “Design Aid 5.16.2”.

Page 5–126, left column, first paragraph: Replace “Design Aids 5.15.3 and 5.15.4” with “Design Aids 5.16.3 and 5.16.4”.

Page 5–126, left column, second paragraph: Replace “Design Aids 5.15.3 and 5.15.4” with “Design Aids 5.16.3 and 5.16.4”.

Page 5–126, right column, last paragraph, line 10: Delete “(Section 14.1)”.

Page 5–127, Example 5.10.2.1, heading: Replace “Use of Design Aids 5.15.3 and 5.15.4” with “Use of Design Aids 5.16.3 and 5.16.4”.

Page 5–127, Example 5.10.2.1, under “*Problem*”: Replace “Design Aid 5.15.4” with “Design Aid 5.16.4”.

Page 5–132, left column, third paragraph under “5.10.6.2 Strength Design”, line 3: Replace “(MNL-133-12)” with “(MNL-133-11)”.

Page 5–155, reference 39: Replace “MNL-133-12” with “MNL-133-11”. [*Note: This only occurs in the print version and not the PDF version.*]

Chapter 6

Page 6–5, left column, second line: Replace “Table 21.2.1[g]” with “Table 21.2.1[h]”.

Page 6–9, Example 6.4.9.1, under “Case 1: For edge perpendicular to load.”: Replace

$$“\psi_{ec,v} = 0.7 + 0.3 \frac{C_{a2}}{1.5C_{a1}} \leq 1.0” \text{ with } “\psi_{ed,v} = 0.7 + 0.3 \frac{C_{a2}}{1.5C_{a1}} \leq 1.0”$$

Page 6–19, Example 6.5.2.1, equation to calculate ϕN_p : Replace “ s_1 ” with “ s ”.

Page 6–19, Example 6.5.2.1: Replace figure on the left with the following:

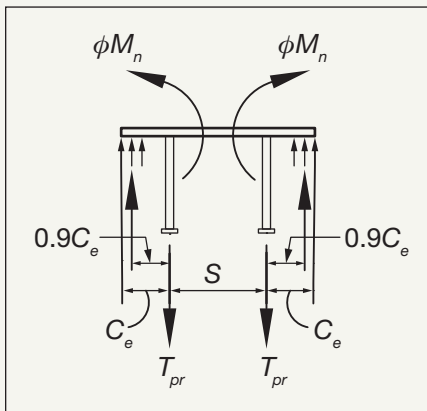

Page 6–19, Example 6.5.2.1, equation to calculate T_{pr} : Replace “ s_1 ” with “ s ”.

Page 6–19, Example 6.5.2.1, equation to calculate ϕN_{pf} : Replace “ s_1 ” with “ s ”.

Page 6–27, Example 6.5.4.1, under “Solution”, after “From Fig. 6.5.2, Case 4-3.”: Delete “-3” to change to “From Fig. 6.5.2, Case 4”.

Page 6–27, Example 6.5.4.1, below “From Eq. 6-10.”: Replace “($\phi = 0.70$; see condition B, Section 6.2.1.3)” with “($\phi = 0.70$; see Section 6.5.4.2)”.

Page 6–27, Example 6.5.4.1, after “From Eq. 6-10.”: Replace “ N_{nh} ” with “ N_{ph} ”.

Page 6–28, Example 6.5.4.1, line 3: Replace “From Eq. 5-29” with “From Eq. 5-35”.

Page 6–28, Example 6.5.4.1, line 5: Replace “From Eq. 5-28b” with “From Eq. 5-34”.

Page 6–30, Example 6.5.5.1, after “X-spacing factor”: Insert 3 in denominator before “BED” as such:

$$C_{x3} = 0.85 + \frac{X}{3BED}$$

Page 6–33, Example 6.5.5.2, under “Solution”: Replace “Check for corner condition by Eq. 6-17” with “Check for corner condition by Eq. 6-20”.

Page 6–33, Example 6.5.5.2, under “Solution,” after “Steel strength (same as Example 6.5.5.1):”: Replace “ $\phi V_s = 33.8$ kip” with “ $\phi V_s = 19.3$ kip”.

Page 6–34, Example 6.5.5.3, title: Replace “Corner-Failure” with “Side-Failure”.

Page 6–34, Example 6.5.5.3, below “Solution”: Replace “Eq. 6-20” with “Eq. 6-24”.

Page 6–34, Example 6.5.5.3, below “Solution”: Replace “ $\frac{SED}{BED} \leq 0.2$ ” with “ $\frac{SED}{BED} < 0.2$ ”.

Page 6–34, Example 6.5.5.3, after “Steel strength”: Delete “(same as Example 6.5.5.1)” and replace “ $\phi V_s = 33.8$ kip” with “From Eq. 6-4: $\phi V_s = \phi n A_{se} f_{ut} = 0.65 (4)(0.2)(65) = 33.8$ kip”.

Page 6–57, right column, Eq. 6-51 and 6-52 variable definitions, in the equation for $M_{u,resultant}$: Replace “ V_{ue} ” with “ $V_u e$ ”.

Page 6–59, Example 6.6.6.1, under step 1.2: Replace calculation result of 50.5 with 50.6.

Page 6–59, Example 6.6.6.1, under “From Eq. 6-51.”: Revise equation as follows:

$$V_u \cos \theta / \phi P_n + V_u [e - \cos \theta (b'/2)] / \phi M_n \leq 1.0$$

Page 6–64, Example 6.7.3.1, under “Solution”: Replace “(1) Carbon equivalent CE from Eq. 6-59” with “(1) Carbon equivalent CE from Eq. 6-64”.

Page 6–65, Figure 6.7.3: Replace “ $e_x(-)$ ” with “ $e_x(+)$ ” and “ $e_z(-)$ ” with “ $e_z(+)$ ”.

Page 6–76, Example 6.8.1: Revise calculation as follows:

$$\phi V_n = \phi(0.6)F_y A_w = 0.9(0.6)(46)[2(6 - 3(0.465))(0.465)] = 106.4 \text{ kip}$$

Page 6–78, left column, line 2: Replace “ f_y ” with “ f_{yr} ” and “(Eq. 5-25)” with “(Eq. 5-29)”.

Page 6–78, left column, line 3: Replace “ f_y ” with “ f_{yr} ” and add “(Eq. 5-30)”.

Page 6–78, right column, step 7, line 2: Replace “Section 5.6.1” with “Section 5.5.1”.

Page 6–79, left column, step 11, line 7: Replace “(Eq. 5-29)” with “(Eq. 5-35)”.

Page 6–79, Example 6.9.1, under “Design Strap”: Replace “Use $3/8 \times 3\frac{1}{2}$ in. strap” with “Use $3/8 \times 3$ in. strap”.

Page 6–79, Example 6.9.1: Revise calculation as follows: $A_s = 0.375(2)(3-5 \ 3.0) = 2.63 \ 2.25 \text{ in}^2$.

Page 6–79, Example 6.9.1, under “Check shear”: Revise as follows:

Check shear: [Note: $t_{des} = 0.93t_n$ per AISC 360 Section G5.]

$$F_{actual} = V_u / (Y - 3t)(2t) = 36 / \left(4 - 3 \left(0.93 \left(\frac{5}{16} \right) \right) \right) \left(2 \left(0.93 \left(\frac{5}{16} \right) \right) \right) = 19.8 \text{ ksi}$$

Page 6–80, Example 6.9.1, left column under “Check minimum shear reinforcing”: Replace “Eq. 5-25” with “Eq. 5-29” and “ f_y ” with “ f_{yr} ”, and replace “Or” with “Or by Eq. 5-30” and “ f_y ” with “ f_{yr} ”.

Page 6–80, Example 6.9.1, right column under “Design bottom dowel”: Replace “Eq. 5-29” with “Eq. 5-35”.

Page 6–80, Example 6.9.1, right column, below “Design Aid 6.15.3 (E70 electrode)”: Replace “ $\ell_w = 3\frac{1}{2}$ in.” with “ $\ell_w = 3$ in.”.

Page 6–80, Example 6.9.1, right column, under “If anchor reinforcement is not provided, concrete breakout strength must be checked”: Revise example as follows:

$$BED = h = 14.16 \text{ in.}$$

$$SED = \frac{(b_w - b - t_s)}{2} = \frac{(8 - 4 - 0.375)}{2} = 1.81 \text{ in.}$$

$$V_{CO3} = 16.5\lambda\sqrt{f'_c} (BED)^{1.33} = \frac{16.5\sqrt{5000} (14.16)^{1.33}}{1000} = 39.046.6 \text{ kip}$$

$$C_{c3} = 0.7^3 \sqrt{\frac{SED}{BED}} = 0.7^3 \sqrt{\frac{1.81}{14.16}} = 0.350.34$$

$$\phi V_{C3} = \phi V_{CO3} C_{c3} = 0.75 (39.046.6) (0.350.34) = 10.211.8 \text{ kip}$$

$$V_{u,all} = \frac{(10.211.8)}{1.33} = 7.678.9 \text{ kip} < V_u = 36.0 \text{ kip}$$

Page 6–84, Figure 6.10.3: Replace “Shape factor = $\sqrt{5000 / f'_c}$ ” with “Shape factor = $S = \frac{wb}{2(w+b)t}$ ”.

Page 6–90, Example 6.11.2.1, under “Concrete breakout strength (Eq. 6-6)”: Replace “From Eq. 6-4” with “From Eq. 6-7”.

Page 6–100, Example 6.13.3, under “Double-tee deck plate (see previous example)”: Replace “ $\phi V_n = 20.4 \text{ kip}$ ” with “ $\phi V_n = 19.4 \text{ kip}$ ” and correct the corresponding value in the summary table.

Page 6–103, Example 6.13.5, within “Given”: Add “ $\phi = 0.75$ for DBA based on brackets and corbels”.

Page 6–103, Example 6.13.5, below “Solution” step 1a: Replace “Design Aid 15.2.9” with “Design Aid 15.3.2”.

Page 6–103, Example 6.13.5, after “Solution” step 1b: Replace “(see Section 5.3.5)” with “(see Section 5.3.4)”, and replace “Deriving from Eq. 5-28a” with “Deriving from Eq. 5-33”.

Page 6–103, Example 6.13.5, under “Solution” step 1c: Delete “From Eq. 5-30”.

Page 6–109, reference 16: Replace “American Institute of Steel Construction (AISC). 2017. *Steel Construction Manual*, 15th ed. Chicago, IL: AISC.” with “American Institute of Steel Construction (AISC). 2011. *Steel Construction Manual*, 14th ed. Chicago, IL: AISC.” [Note: This only occurs in the PDF version and not the print version.]

Page 6–111, Design Aid 6.15.3, footnote d: Replace “Design Aid 15.7.2” with “Design Aid 15.6.2”.

Page 6–112, Design Aid 6.15.4, footnote b: Replace “Design Aid 15.7.2” with “Design Aid 15.6.2”.

Page 6–112, Design Aid 6.15.5, equation for ℓ_w : Replace “ $2\pi\left(d_b + \frac{a}{2}\right)$ ” with “ $\pi\left(d_b + \frac{a}{2}\right)$ ”.

Page 6–112, Design Aid 6.15.5, footnote b, second bullet under “Failure modes include”: Replace “[$\phi(0.6F_y)$] $\ell_w(t_{pl})$ ” with “[$\phi(0.6F_y)$] $[\pi(d_b + 2a)t_{pl}]$ ”.

Page 6–112, Design Aid 6.15.5, footnote b, third bullet under “Failure modes include”: Replace “[$\phi(0.6F_u)$] $\ell_w(t_{pl})$ ” with “[$\phi(0.6F_u)$] $[\pi(d_b + 2a)t_{pl}]$ ”.

Page 6–113, Design Aid 6.15.6, equation for ℓ_w : Replace “ $2\pi\left(d_b + \frac{a}{2}\right)$ ” with “ $\pi\left(d_b + \frac{a}{2}\right)$ ”.

Page 6–113, Design Aid 6.15.6, footnote b, second bullet under “Failure modes include”: Replace “[$\phi(0.6F_y)$] $\ell_w(t_{pl})$ ” with “[$\phi(0.6F_y)$] $[\pi(d_b + 2a)t_{pl}]$ ”.

Page 6–113, Design Aid 6.15.6, footnote b, third bullet under “Failure modes include”: Replace “[$\phi(0.6F_u)$] $\ell_w(t_{pl})$ ” with “[$\phi(0.6F_u)$][$\pi(d_b + 2a)t_{pl}$]”.

Page 6–114, Design Aid 6.15.7, footnote c: Replace “Design Aid 15.6.3” with “Design Aid 15.5.3”.

Page 6–114, Design Aid 6.15.7, footnote d: Replace “Design Aids 15.6.1 and 15.6.2” with “Design Aids 15.5.1 and 15.5.2”.

Page 6–116, Design Aid 6.15.9, line 8: Replace “Design Aid 6.15.7” with “Design Aid 6.15.8”.

Page 6–117, Design Aid 6.15.11, Case 1, equation for ϕN_{cb} : Insert “ ϕ ” before “ C_{bs} ”.

Page 6–120, Design Aid 6.15.11, under Case 4, line 3: Replace “from Table 6.5.4” with “from Table 6.5.3”.

Page 6–120, Design Aid 6.15.11, Case 4, Table A heading: Insert “ $d_{e3} +$ ” so the second parenthetical term is “($d_{e3} + Y + 1.5h_{ef}$)”.

Page 6–122, Design Aid 6.15.11, Case 6: Replace figure with the following:

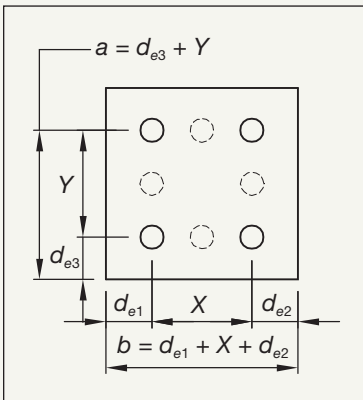

Chapter 8

Page 8–6, Figure 8.3.2, under “(b) Eight-point pick-up maximum moments”: Replace “ $+M_y = -M_y = 0.00054wab^2$ ” with “ $+M_y = -M_y = 0.0054wab^2$ ”.

Page 8–27, right column, second paragraph under “8.7.2 Responsibilities”, line 2: Replace “Section 14.5” with “Section 14.2”.

Chapter 10

Page 10–13, Example 10.6.3.1, after “From Eq. 5-1”: Insert “ $f_{ps\theta}$ ” before bracket in equation for “ $f_{ps\theta}$ ” as follows:

$$f_{ps\theta} = f_{pu\theta} \left[1 - \frac{\gamma_p A_{ps} f_{ps\theta}}{\beta_1 b d f_c} \right]$$

Page 10–13, Example 10.6.3.1; Revise calculation as follows:

$$a_\theta = \frac{A_{ps} f_{ps\theta}}{0.85 f_c b} = \frac{1.224 (135.6 - 138.7)}{0.85 (5) (12)} = 3.33 \text{ in.}$$

Page 10–14, Example 10.6.3.1, after “From Eq. 5-1”: Replace “ $f_{ps\theta}$ ” on right side of equal sign with “ $f_{pu\theta}$ ”.

Chapter 11

Page 11–7, Table 11.1.3, fourth column: Under "Miscellaneous", then "Plaster", then "gypsum, lightweight aggregate", replace "0.33" with "–".

Page 11–7, Table 11.1.3, fourth column: Under "Miscellaneous", then "Roofing, 3/8 in. built-up", replace "–" with "0.33".

Chapter 12

Page 12–11, Figure 12.8.1: Replace " $\theta > 5$ deg." with " $\theta \geq 5$ deg."

Chapter 13

Page 13–3, right column, under "Drawings": Replace "Section 14.4.6" with "Section 14.1.6".

Page 13–4, left column, under "Specially finished structural precast concrete", line 6: Replace "Section 14.4.4.3" with "Section 14.1.4.3".

Chapter 15

Page 15–34, Design Aid 15.3.2, top table: Insert "with $\Psi_c = 0.7$ " after "General Use".

Page 15–34, Design Aid 15.3.2, bottom table: Insert "with $\Psi_c = 0.7$ and $\Psi_r = 0.8$ " after "Special Confinement".

Appendix C

Page C–4, left column, Eq. C-9a: Replace " S_{DS} " with " S_{DI} ".

Page C–4, left column, after Eq. C-9b: Insert "where n = number of stories above the base".

Page C–5, right column, last paragraph, first line: Replace "Table 12.11.5-1" with "Table 12.10-1".

Page C–5, right column, last paragraph, third line: Replace "Section 12.11.5" with "Section 12.10.3.5".

Reference

1. ACI (American Concrete Institute) Committee 318. 2014. *Building Code Requirements for Structural Concrete (ACI 318-14) and Commentary (ACI 318R-14)*. Farmington Hills, MI: ACI.