

3.6 Hollow-Core Load Tables (cont.)

Strand Pattern Designation

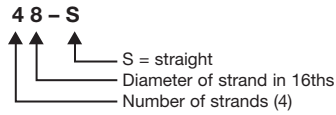

Load capacities shown include dead load of 10 lb/ft² for untopped members and 15 lb/ft² for topped members. Remainder is live load. Long-time cambers include superimposed dead load but do not include live load.

Capacity of sections of other configurations are similar. For precise values, see local hollow-core manufacturer.

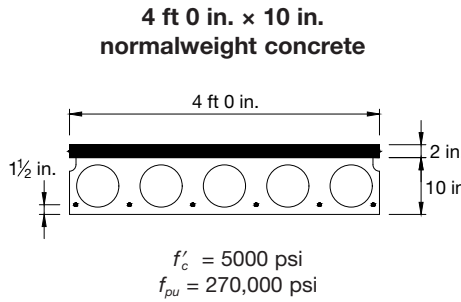

Section Properties	
No topping	2 in. topping ($f'_c = 3000$ psi)
A =	259 in. ²
I =	3223 in. ⁴
y_b =	5.00 in.
y_t =	5.00 in.
S_b =	645 in. ³
S_t =	645 in. ³
wt =	270 lb/ft
DL =	68 lb/ft ²
V/S =	2.23 in.
b_w	10.5 in.

- Key
210 – Superimposed service load capacity, lb/ft²
0.3 – Estimated camber at erection, in.
0.4 – Estimated long-time camber, in.

Table of superimposed service load capacity, lb/ft², and cambers, in.

4HC10
No topping

Strand pattern	Span, ft																											
	20	21	22	23	24	25	26	27	28	29	30	31	32	33	34	35	36	37	38	39	40	41	42	43	44	45	46	
48-S	210	198	185	174	164	151	136	123	111	100	90	82	74	66	60	54	48	43	38	34	30	26						
	0.3	0.3	0.3	0.3	0.3	0.3	0.3	0.3	0.3	0.2	0.2	0.2	0.1	0.1	0.0	-0.1	-0.2	-0.3	-0.4	-0.6	-0.7	-0.9						
58-S	267	249	237	223	211	197	179	162	148	134	122	112	102	93	85	77	70	64	58	53	48	43	39	35	30	26		
	0.4	0.4	0.4	0.4	0.4	0.4	0.3	0.3	0.2	0.2	0.1	0.0	-0.1	-0.2	-0.3	-0.5	-0.7	-0.8	-1.1	-1.3	-1.3	-1.9						
68-S	273	255	243	229	217	206	196	187	176	162	153	141	129	118	109	100	92	84	78	71	65	60	54	49	44	39	34	
	0.5	0.5	0.6	0.6	0.6	0.7	0.7	0.7	0.7	0.7	0.7	0.7	0.7	0.7	0.6	0.6	0.5	0.5	0.4	0.3	0.2	0.1	-0.1	-0.2	-0.4	-0.6	-0.8	
78-S	282	264	249	235	223	212	202	193	185	174	165	153	144	136	129	119	113	104	96	89	82	76	69	63	57	52	47	
	0.6	0.7	0.7	0.7	0.8	0.8	0.9	0.9	0.9	0.9	0.9	1.0	1.0	1.0	0.9	0.9	0.9	0.8	0.8	0.7	0.6	0.5	0.4	0.3	0.1	0.0	-0.2	
88-S	288	270	255	241	229	218	208	199	188	180	174	165	153	145	135	128	122	115	106	101	96	91	84	77	71	65	59	
	0.7	0.8	0.8	0.9	0.9	1.0	1.0	1.1	1.1	1.1	1.2	1.2	1.2	1.2	1.2	1.2	1.2	1.2	1.2	1.1	1.1	1.0	0.9	0.8	0.7	0.5	0.3	

Table of superimposed service load capacity, lb/ft², and cambers, in.

4HC10 + 2
2 in. normalweight topping

Strand pattern	Span, ft																											
	20	21	22	23	24	25	26	27	28	29	30	31	32	33	34	35	36	37	38	39	40	41	42	43	44	45	46	
48-S	255	238	223	209	197	181	163	146	131	117	107	96	86	74	63	52	43	34	26									
	0.3	0.3	0.3	0.3	0.3	0.3	0.3	0.3	0.3	0.2	0.2	0.1	0.1	0.0	-0.1	-0.2	-0.3	-0.4	-0.6	-0.7	-0.9							
58-S	317	298	282	267	252	237	219	198	180	163	148	134	120	105	92	80	69	59	50	41	33	26						
	0.4	0.4	0.4	0.4	0.5	0.5	0.5	0.5	0.5	0.5	0.5	0.4	0.4	0.4	0.3	0.2	0.2	0.1	0.0	-0.1	-0.3	-0.4						
68-S	326	307	291	273	258	246	234	222	212	202	188	171	153	137	122	108	96	84	74	64	55	46	38	31				
	0.5	0.5	0.6	0.6	0.6	0.7	0.7	0.7	0.7	0.7	0.7	0.7	0.7	0.7	0.6	0.6	0.5	0.5	0.4	0.3	0.2	0.1	-0.1	-0.2				
78-S	335	313	297	279	267	252	240	228	218	208	196	189	181	165	150	135	122	109	97	86	76	67	58	50	42	35	28	
	0.6	0.7	0.7	0.7	0.8	0.8	0.9	0.9	0.9	0.9	0.9	1.0	1.0	1.0	0.9	0.9	0.9	0.8	0.8	0.7	0.6	0.5	0.4	0.3	0.1	0.0	-0.2	
88-S	344	322	306	288	273	258	246	234	221	211	202	195	184	178	172	158	144	130	118	107	96	87	77	68	60	52	44	
	0.7	0.8	0.8	0.9	0.9	1.0	1.0	1.1	1.1	1.1	1.2	1.2	1.2	1.2	1.2	1.2	1.2	1.2	1.2	1.1	1.1	1.0	0.9	0.8	0.7	0.5	0.3	

Strength is based on strain compatibility; bottom tension is limited to $7.5 \sqrt{f'_c}$; see pages 3-8 through 3-11 for explanation.

See Section 3.3.2, Item 3, Note 4 for explanation of vertical line.