

PCI Design Handbook

Precast and Prestressed Concrete, Sixth Edition

In 2004, the Precast/Prestressed Concrete Institute published the sixth edition of the PCI Design Handbook—Precast and Prestressed Concrete (MNL-120-04). Although careful efforts were made to provide an accurate document, some errors have been discovered. We suggest that you mark your sixth edition to reflect these errata so that use of the handbook is accurate.

As this edition of the handbook is used, additional errata may be discovered. You are urged to notify PCI of these items, as well as any questions or comments you may have regarding the material in the handbook. Also, any comments on new material you feel should be included in future editions are equally welcome.

Please direct your comments to PCI's Technical Activities Director at PCI headquarters.



Precast/Prestressed Concrete Institute

209 West Jackson Boulevard | Suite 500 | Chicago, IL 60606
Phone: 312-786-0300 | Fax: 312-786-0353 | www.pci.org

1. Index: All Chapter 10 references indicate the item is two pages after where it actually occurs.
2. Page 1-29: In the left column, fourth paragraph, first sentence, the word “comcete” should be changed to “concrete”.
3. Page 2-12: In the section properties for the untopped member, the self-weight DL should be 52 psf in lieu of 50 psf.
4. Page 2-13: In the section properties for the untopped system, the value for the weight “wt” should be changed from “418 plf” to “320 plf”.
5. Page 2-16: In the section properties for the untopped member, the self-weight DL should be 47 psf in lieu of 74 psf.
6. Page 2-53: The voids in the hollow-core sandwich wall panel diagram should be located graphically, within the top wythe.
7. Page 3-20: In the top table, left column, the text should be changed as follows: Change “Panel Upper” to “Panel”, change “Window Lower” to “Upper Window”, change “Window” to “Lower Window”. Where the horizontal dead load to the connection is calculated, change the result from “ $774.7/2 = 387$ ” to “774.7”.
8. Page 3-21: In the table under the heading “Dead Load”, the force values listed as “484” should be changed to “930”.
9. Page 3-35: In Figure 3.5.5.1, diagram (b), the shear-wall locations should not appear to be shifted right from their original location.
10. Page 3-37: Equation 3.5.7.1 should change from “ $(k_i / \sum r) /$ ” to “ $(k_i / \sum r)V_x$ ”.
11. Page 3-37: In Equations 3.5.7.2 and 3.5.7.3, “T” should be replaced with “ e_x ”. In the definitions below, “ e_x ” should be defined as the distance between the center of the load in the “Y” direction, and the center of stiffness measured in the “X” direction.
12. Page 3-39: In Example 3.5.7.1, in the fifth line, “ V_x ” should be changed to “ V_y ”.
13. Page 3-43: Near the middle of the page where the wind force is calculated, the term “ $1.6(32.2/2) = 25.8$ kips” should be changed to “ $1.6(30.4/2) = 24.3$ kips”. In the next line the value of “25.8 kips” should also be replaced with “24.3 kips”.
14. Page 3-73: In the table, far right column, the values for “ F_x ” listed from top to bottom should be changed to: “118, 80, 60, 42, 28, 16, 8, 2, and 354”.
15. Page 3-88: Just above Equation 3.8.3.1, the reference to the section in IBC 2003 should be changed from “1620.1.5” to “1620.2.5”.
16. Page 3-97: Bottom of left column, in “Item 1” the reference to the equation in IBC 2003 should be changed from “16-65” to “16-63”.
17. Page 3-111: In Figure 3.10.7, part C, the first line of the table should read “Mapped Spectral Response Acceleration at 1-Second Periods”.
18. Page 4-48: In step 2 of the *Solution*, third line, the term “ P_x ” should be changed to “ $P_u(x)$ ”.
19. Page 4-52: Example 4.3.4.1, in the statement of the problem, change “Code Eq. 1114” to “Code Eq. 11-14”.
20. Page 4-55: Example 4.3.5.1, in the second line after “The topping reinforcement is:”, change “= 0.58 in” to “= 0.70 in”. In the line beginning “ C_c ”, change “(285.6)” to “(380.8)” and change “81.6” to “108.8”. In the line beginning “ μ_e ”, change “81,600” to “108,800”, and change “4.94” to “3.7”. In the line beginning “ A'_{cs} ”, change “81.6” to “108.8”, change “= 0.53” to “= 0.71”, and change “< 0.58” to “ ≈ 0.70 ”. In the line beginning “ $A'_{cs,min}$ ”, change “< 0.53” to “< 0.70”.
21. Page 4-56: Table 4.3.6.1, revise the heading of right column to “Maximum V_u/ϕ ”.
22. Page 4-60: In the denominator of Equation 4.4.3, the term “ V_n ” should be changed to “ V_u ”.
23. Page 4-81: On the left side, near the top of the page, in the equation for “ μ_e ”, the term “ μ ” should be normal size, not a subscript to “h”.
24. Page 4-85: On the left side, halfway down, in the definition of “R.H.”, the reference “Figure 3.12.2” should be changed to “Figure 3.10.12”.
25. Page 4-100: In the box on the upper right, last line of the equation for “ M_n ”, “ $(d - y_t)$ ” should be “ $(d_p - y_t)$ ”.
26. Page 4-108: In the line under “Problem:”, the reference to Figure 2.6.5 should be changed to Figure 2.7.5.
27. Page 4-109: Near the middle of the page, the reference to the interaction diagram of Figure 2.6.5 should change to Figure 2.7.5.
28. Page 4-109: In line 17, change “Prestress = 250 psi” to “Prestress = 225 psi”.
29. Page 4-109: In line 19, change “Net stress (compression) = 252 psi” to “Net stress (compression) = 227 psi”.
30. Page 4-110: In the equation after “Deflection due to P – Δ moment at midspan”, the value for “EI” should be changed from “ 1.23×10^7 ” to “ 7.9×10^6 ”. This also affects the calculations that follow: the P-Delta multiplier “0.028e” changes to “0.044e”; the three iterations of calculations are affected by this errata resulting in a final midspan deflection of “1.362 in.”. However, the calculated moment “ M_u ” (after round-off) is unchanged.

31. Page 4-110: In line 18, change “Prestress = 250 psi” to “Prestress = 225 psi”.
32. Page 4-110: In line 20, change “Net Stress (tension) = -7 psi” to “Net Stress (tension) = -32 psi”.
33. Page 4-110: In line 21, change “7 psi” to “32 psi”.
34. Page 4-110: At the bottom of the page, the reference to the interaction diagram of Figure 2.6.5 should change to Figure 2.7.5.
35. Page 5-25: In Example 5.6.1, the denominator in the calculation of “f” should change from “635” to “640”. This will change the result from “1.58” to “1.57”.
36. Page 5-25: In Example 5.6.1, first sentence following the calculations, change “a” to “an”.
37. Page 6-11: In the right column in equation 6.5.1.1, change “t_p” to “t_p”.
38. Page 6-14: In Figure 6.5.4.1(d), all three references to “d_{e2}” should be changed to “d_{e3}”.
39. Page 6-23: Eq 6.5.5.15 should read $C_{x1} = n_x$ (i.e. “x₁” in lieu of “x₁”).
40. Page 6-23: In the right column, 10th line, add the word “factor” behind the word “X-spacing”.
41. Page 6-23: On the right side, the second equation for “C_{y1}” (where “n_y > 1.0”), the end of the equation should be changed from “≤ 1.0” to “≤ n_y”.
42. Page 6-25: The end portion of the equation for “Ψ_y”, including “= 1.0 for y = 0”, should be moved to the next line:
- $$\Psi_y = \frac{\sqrt{y}}{4d_o} \text{ for } \frac{y}{d} \leq 20$$
- $$= 1.0 \text{ for } y = 0$$
43. Page 6-25: In the right column, for the definition of the variable “φ”, eliminate the line of text that reads “= 0.75 with confinement reinforcement”.
44. Page 6-27: In the sketch, the term “N_{hu} = 4 kips” should be changed to “N_u = 4 kips”. The symbol “N_{hu}” should be added to the arrow pointing to the left.
45. Page 6-27: In line 18, “Ψ_{ec,N}” should be changed to “Ψ_{ed,N}”.
46. Page 6-31: In the right column, delete the first sentence and the formula. This material appears at the bottom of the left column.
47. Page 6-31: In Example 6.6.3.1, in the calculations for “Combined direct and torsional shear stresses”, the following revisions should be made: In the “Given” section, the value for “w” should be changed from “7.5 in.” to “7.535 in.”, and the value for “d” should be changed from “5.5 in.” to “5.535 in.”. Where calculating “A_w”, change “0.5” to “0.465”, which changes the result to “7.44”. Where calculating “Ā”, change to “Ā = (5.535)(7.535) = 41.71 in.²”. In the equation on the next line, change the numerator from “W_u” to “W_u”. The numerical calculation following this equation should change to
- $$\frac{3.0(8.5)}{2(7.44)} + \frac{51}{(2)(41.71)(.465)}$$
- $$= 1.71 + 1.31 = 3.03 \text{ ksi}.$$
48. Page 6-32: in Example 6.6.3.1 where calculating the Torsional Constant J_T, both the numerator and denominator the values shown as “7.5” and “5.5” should be changed to “7.535” and “5.535”, respectively. This will change the result from “121.7” to “123.8”. Two lines below where “θ” is being calculated, the value in the denominator “121.7”, should be changed to “123.8”, which changes the result from “0.00046 radians” to “0.00045 radians”.
49. Page 6-43: The mathematical expression for “r_{critical}”, which is written as
- $$\left[\frac{r}{\Delta_u(\theta)} \right]$$
- should be eliminated from the text.
50. Page 6-45: At the top of the sketch the element width should be changed from “¼” to “½”.
51. Page 6-45: The table is incorrect. See Appendix A, attached.
52. Page 6-46: The table is incorrect. See Appendix A, attached.
53. Page 6-46: In the table, change “Δ_u/R” to “Δ_u/r”.
54. Page 6-46: Below the table, the variable “x̄” should be removed from the denominator in the equation for “R”.
55. Page 6-48: In Figure 6.8.1.1, item 2, in the first line, “12d” should be changed to “12d_b”. In the next line, “A” should be changed to “A_s”.
56. Page 6-49: Example 6.8.1.1, line after “From Table 4.3.6.1.”, revise to “max V_u = φ(1000)λ²A_{cr} = 0.75(1000)(1)²(14)(14)/1000 = 147 kips > 80.0 kips OK”.
57. Page 6-56: In the right column, fourth line, change the formula to read “0.5V_u/(0.85f_cb)”.
58. Page 6-72: In Example 6.14.1 uses forces determined in Example 3.2.4.2. The seismic force of 3368# already included (in Example 6.14.1) the “0.48W_p” multiplier; therefore, the calculated values presented in the table under the heading “Seismic Design Load” are incorrect. The “5.05 kips” force should be “10.52 kips” and the “1.62 kips” force should be “3.368 kips”. See Appendix B of this document indicates the revisions to the affected values.

59. Page 6-73: In the first line, change the word “throat size” to “fillet weld”.
60. Page 6-75: The calculation for “a” at the top of the page should read “ $\frac{3}{2} - x_l$ ”. This will also change the result in the calculation of “a” from “0.458” to “0.333”.
61. Page 6-76: In the upper right corner of the page, the annotation of the plate embedded in the DT flange should be changed from “(2) #4 × 2'-0”” to “(2) #5 × 2'-0””.
62. Page 6-77: In the lower right corner of the page, the annotation of the plate should be changed from “#4 × 2'-0”” to “#5 × 2'-0””. The value in the last row of the table at the bottom of the page should be changed from “12.1 kips” to “20.4 kips”.
63. Pages 6-97 thru 6-101: The values in Table B are incorrect; the second term of Equation 6.5.4.3 was not included. See Appendix C for corrected values.
64. Page 9-23: In the bottom table, left column, the word “Insulation” should be changed to “Inside Surface”.
65. Page 9-47: The strand callout in the diagram of Example 9.3.7.1 should read “270 ksi”, rather than “270 kip”.
66. Page 11-2: In the second sentence of footnote b, “plasterEdition” should be changed to “plastered”.
67. Page 11-4: In footnote b, eliminate the space in “concentrated”.
68. Page 11-26: In the legend at the bottom left corner of the page, change “J” to “J_T”.
69. Page 11-28: For a member with unequal overhangs, bending moment calculation between “B” and “C”, the term “(c - x)” should be changed to “(c + x)”.
70. Page 11-34: The bend diameters “D” for standard hooks are wrong for #9, #10, #11, #14, and #18 bars. The diameter “D” for those bars should be 9", 10", 11", 17 ½", and 22 ½", respectively.

Initial Guess for $R_o = 0.3443$

Ele	L	x (in.)	y (in.)	r (in.)	θ
1	0.5	2.0943	2.5	3.2613	0.6973
2	0.5	1.5943	2.5	2.9651	0.5677
3	0.5	1.0943	2.5	2.7290	0.4126
4	0.5	0.5943	2.5	2.5697	0.2334
5	0.5	0.3443	2.25	2.2762	1.4190
6	0.5	0.3443	1.75	1.7835	1.3765
7	0.5	0.3443	1.25	1.2966	1.3020
8	0.5	0.3443	0.75	0.8253	1.1404
9	0.5	0.3443	0.25	0.4255	0.6280
10	0.5	0.3443	-0.25	0.4255	-0.6280
11	0.5	0.3443	-0.75	0.8253	-1.1404
12	0.5	0.3443	-1.25	1.2966	-1.3020
13	0.5	0.3443	-1.75	1.7835	-1.3765
14	0.5	0.3443	-2.25	2.2762	-1.4190
15	0.5	0.5943	-2.5	2.5697	-0.2334
16	0.5	1.0943	-2.5	2.7290	-0.4126
17	0.5	1.5943	-2.5	2.9651	-0.5677
18	0.5	2.0943	-2.5	3.2613	-0.6973

71. Page 11-34: In the diagram for standard hooks, the arrowhead for the “J” dimension should extend to the outside edge of the rebar. In the diagram for stirrup and tie-hooks, the leg extension beyond the 135 degree hook should be labeled “6d”, in lieu of “6D”.
72. Page 11-40: In the first sentence, eliminate the word “are”.
73. Page 11-51: In the equation for the moment of inertias of beams and channels, “ I_3 ” and “ I_4 ”, the exponent on the sine function is in the wrong place. It should read “ $\sin^2\phi$ ” not “ $\sin\phi^2$ ”.
74. Page 11-54: In the left column, first sentence, change “Design Aid 11.4.1” to “Design Aid 11.6.2”.

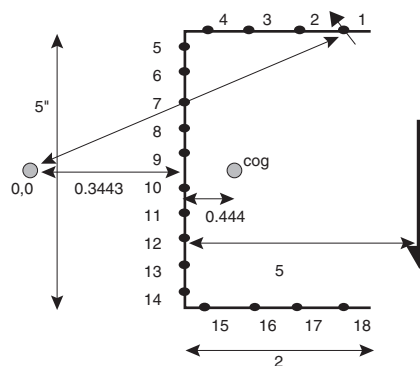

APPENDIX A

COG = 0.444

Weld Size, $a = 0.25$

$r_{crit} = 3.2613$

$e = 5$

	θ°	Δ _{max}	Δ _u	Δ _u Limit	Δ _u	Δ _u /r	Δ _i	Δ _i /Δ _{max}	R _i (kips)	R _x (kips)	R _y (kips)	M _i (kip-in.)
	39.9536	0.0158	0.0226	0.0425	0.0226	0.0069	0.02132	1.3486	4.5603	3.4958	2.9285	14.8725
	32.5265	0.0168	0.0253	0.0425	0.0253	0.0085	0.01938	1.1520	4.4367	3.7407	2.3855	13.1551
	23.6400	0.0185	0.0300	0.0425	0.0300	0.0110	0.01784	0.9640	4.1776	3.8271	1.6752	11.4008
	13.3721	0.0218	0.0396	0.0425	0.0396	0.0154	0.01679	0.7706	3.8340	3.7301	0.8867	9.8521
	81.3000	0.0127	0.0149	0.0425	0.0149	0.0065	0.01488	1.1723	5.5207	5.4572	0.8351	12.5662
	78.8696	0.0128	0.0152	0.0425	0.0152	0.0085	0.01166	0.9099	5.4892	5.3859	1.0596	9.7902
	74.6003	0.0130	0.0157	0.0425	0.0157	0.0121	0.00847	0.6501	5.2179	5.0306	1.3856	6.7653
	65.3417	0.0136	0.0170	0.0425	0.0170	0.0206	0.00539	0.3971	4.5929	4.1741	1.9162	3.7903
	35.9838	0.0163	0.0239	0.0425	0.0239	0.0563	0.00278	0.1704	3.1621	1.8579	2.5587	1.3455
	-35.9838	0.0163	0.0239	0.0425	0.0239	0.0563	0.00278	0.1704	3.1621	-1.8579	2.5587	1.3455
	-65.3417	0.0136	0.0170	0.0425	0.0170	0.0206	0.00539	0.3971	4.5929	-4.1741	1.9162	3.7903
	-74.6003	0.0130	0.0157	0.0425	0.0157	0.0121	0.00847	0.6501	5.2179	-5.0306	1.3856	6.7653
	-78.8696	0.0128	0.0152	0.0425	0.0152	0.0085	0.01166	0.9099	5.4892	-5.3859	1.0596	9.7902
	-81.3000	0.0127	0.0149	0.0425	0.0149	0.0065	0.01488	1.1723	5.5207	-5.4572	0.8351	12.5662
	-13.3721	0.0218	0.0396	0.0425	0.0396	0.0154	0.01679	0.7706	3.8340	-3.7301	0.8867	9.8521
	-23.6400	0.0185	0.0300	0.0425	0.0300	0.0110	0.01784	0.9640	4.1776	-3.8271	1.6752	11.4008
	-32.5265	0.0168	0.0253	0.0425	0.0253	0.0085	0.01938	1.1520	4.4367	-3.7407	2.3855	13.1551
	-39.9536	0.0158	0.0226	0.0425	0.0226	0.0069	0.02132	1.3486	4.5603	-3.4958	2.9285	14.8725
										0.0000	31.2623	167.0761

R (based on Moment) = 31.2623

Difference = 0.0002

Iterate R_x until R (based on moment) = Sum R_x

Factored Load = 23.4469

APPENDIX B

EXAMPLE 6.14.1

Cladding Connections — Reference Examples 3.2.3.1 and 3.2.4.2

Given:

Cladding tension-compression tieback connection of Examples 3.2.3.1 and 3.2.4.2.

Loads—from “Summary of Factored Loads to Connections (lb)” Example 3.2.4.2:

Seismic: 3368 lb (in or out). Based on $0.48 W_p$.
 Wind: 4184 lb (out)
 Concrete: $f'_c = 5000$ psi
 Steel: $F_y = 36$ ksi; $F_u = 58$ ksi
 Weld: E70

Problem:

Size the components for the design loads listed.

Solution:

Apply connection factors (seismic only) shown at right:

From example 3.2.4.2:

$$0.48 W_p = 3.368 \text{ kip}$$

$$1.5W_p = \frac{1.5}{0.48}(3.368) = 10.52 \text{ kip}$$

$$\text{Factored wind load: } \frac{4184}{1000} = 4.18 \text{ kip}$$

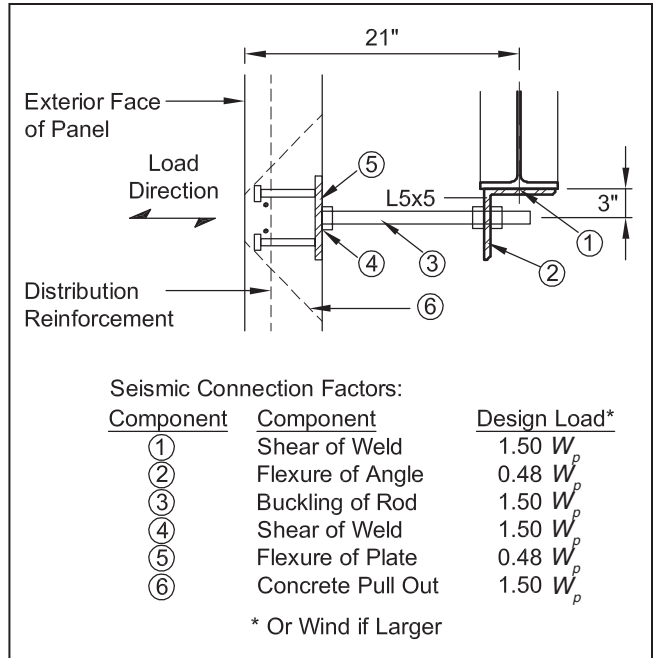

Component	Mode of Failure	Seismic Force	Seismic Design Load	Wind Design Load	Critical Design Load
1	Shear of Weld	$1.50 W_p$	10.52 kip	4.18 kip	10.52 kip
2	Flexure of Angle	$0.48 W_p$	3.37 kip	4.18 kip	4.18 kip
3	Buckling of Rod	$1.50 W_p$	10.52 kip	4.18 kip	10.52 kip
4	Shear of Weld	$1.50 W_p$	10.52 kip	4.18 kip	10.52 kip
5	Flexure of Plate	$0.48 W_p$	3.37 kip	4.18 kip	4.18 kip
6	Flexure of Pullout	$1.50 W_p$	10.52 kip	4.18 kip	10.52 kip

Component 2

Try angle $5 \times 5 \times \frac{7}{16} \times 6$ in. Design shear load = 10.52 kip

Shear Yielding (Eq. 6.6.2.1):

$$\begin{aligned} \phi V_n &= \phi (0.6F_y)A_w \\ &= 0.9(0.6)(36)(\frac{7}{16})(6) \\ &= 51.0 \text{ kips} > 10.52 \text{ kip} \end{aligned}$$

Flexure: Moment arm = 3 kip-in. of angle

$$M_u = 4.18(3 - 0.94) = 8.61 \text{ kip-in.}$$

$$Z = \frac{bt^2}{4} = \frac{6(0.44)^2}{4} = 0.29 \text{ in.}^3$$

$$\phi M_n = \phi Z F_y = 0.9(0.29)(36) = 9.40 \text{ kip-in.} > 8.61 \text{ kip-in.}$$

Component 3 — Connection Rod (see Ref. 6)

$$C_u = T_u = 10.52 \text{ kip}$$

Try $\frac{7}{8}$ in. A36 All-thread rod. $A_s = 0.60 \text{ in.}^2$

Unsupported length, $\ell_u = 21 - 5 - 2.5 = 13.5 \text{ in.}$; $r = \frac{D}{4} = \frac{0.875}{4} = 0.219 \text{ in.}$

$$\lambda_c = \frac{K\ell_u}{r\pi} \sqrt{\frac{F_y}{E}} = \frac{1.0(13.5)}{0.219\pi} \sqrt{\frac{36}{29000}} = 0.69 < 1.5; \lambda_c^2 = 0.48$$

$$\phi C_n = \phi(0.658)^{\lambda_c^2} F_y A_s = 0.85(0.658)^{0.48} (36)(0.60) = 15.0 \text{ kip} > 10.52 \text{ kip}$$

$$\phi T_n = \phi F_y A = 0.9(36) \left(\frac{\pi D^2}{4} \right) = 0.9(36) \left(\frac{\pi(0.875)^2}{4} \right) = 19.4 \text{ kip} > 10.52 \text{ kip}$$

Component 4, Weld Design — Nut Weld

$$T_u = 10.52 \text{ kip}$$

Assumed length of weld is circumference of all thread = πD . Try $\frac{3}{16}$ in. fillet weld.

$$\phi T_s = \phi(0.6F_{\text{exx}})A = \phi(0.6F_{\text{exx}}) \frac{1}{\sqrt{2}} a \ell_w = (0.75)(0.6)(70) \left(\frac{1}{\sqrt{2}} \right) \left(\frac{3}{16} \right) \left[(\pi) \frac{7}{8} \right] = 11.4 \text{ kip} > 10.52 \text{ kip}$$

Component 1, Weld Design — Connection Angle

$T_u = 10.52 \text{ kip}$ at eccentricity of 3 in.

Using the Elastic Vector Method:

Assume two line welds, one at each end of angle welded to structural steel shape.

Weld section properties based on a unit weld size:

$$S_x = \frac{d^2}{3} = \frac{(5)^2}{3} = 8.33 \text{ in.}^2$$

Maximum Tension Stress at end points:

$$f_y = \frac{T_u e_r}{S_x} = \frac{10.52(3)}{8.33} = 3.79 \text{ kip/in.}$$

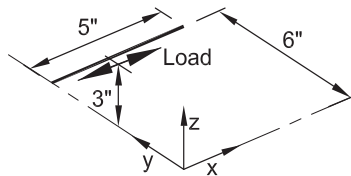

Maximum Shear Stress:

$$f_z = \frac{T_w}{\ell_w} = \frac{10.52}{5+5} = 1.05 \text{ kip/in.}$$

Resultant Stress:

$$f_{\text{result}} = \sqrt{f_x^2 + f_y^2 + f_z^2} = \sqrt{0^2 + 3.79^2 + 1.05^2} = 3.93 \text{ kip/in.}$$

Reduced Design Strength $\frac{1}{4}$ in. Fillet Weld:

$$\phi f_n = \phi(0.6F_{\text{exx}}) \frac{1}{\sqrt{2}} (0.25) = 0.75(0.6)(70) \frac{1}{\sqrt{2}} 0.25 = 5.56 \text{ kip/in.} > 3.93 \text{ kip/in.}$$

Component 5 — Embedded Plate Flexure

Try PL $\frac{3}{8} \times 6 \times 6$ in. w/(4) $\frac{1}{2}$ in. diameter $\times 3$ in. studs at 4 in. on center

$$T_u = 4.18 \text{ kip}$$

$$M_u = \frac{PL}{4} = \frac{(4.18)(4)}{4} = 4.18 \text{ kip-in.}$$

$$\phi M_n = \phi(F_y)Z_p = \phi(F_y)\left(\frac{bd^2}{4}\right) = 0.9(36)\left(\frac{6(0.375)^2}{4}\right) = 6.83 \text{ kip-in.} > 4.18 \text{ kip-in.}$$

Component 6 — Headed Stud Capacity

$$N_u = 10.52 \text{ kip}$$

$$\text{Effective Length } h_{ef} = L + t_{plate} - t_{head} - \frac{1}{8} = 3 + 0.375 - \frac{5}{16} - \frac{1}{8} = 2.94 \text{ in.}$$

Assume not near free edge: $C_{min} \geq 1.5h_{ef}$

Breakout Strength:

$$\phi N_{cb} = C_{bs} A_N C_{crb} \Psi_{ed,N}$$

$$C_{bs} = 3.33 \sqrt{\frac{f'_c}{h_{ef}}} = 3.33 \sqrt{\frac{5000}{2.94}} = 137.4$$

$$A_N = (s + 3h_{ef})(s + 3h_{ef}) = 164.2 \text{ in.}^2 = [4 + 3(2.94)][4 + 3(2.94)] = 164.2 \text{ in.}^2$$

$$C_{crb} = 1.0 \quad C_{crb} = 1.0$$

$$\Psi_{ed,N} = 1.0$$

Panel reinforcement goes through failure surface: $\phi = 0.75$

$$\phi N_{cb} = 0.75(137.4)(164.2)(1.0)(1.0) = 16,921 \text{ LB} = 16.9 \text{ kip} > 10.52 \text{ kip}$$

Connection Detail:

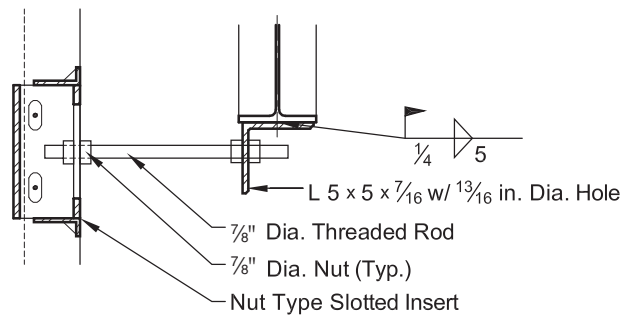

APPENDIX C

Table B. Modification for Edge Distance, $(\Psi_{ed,N})$

$L_s \backslash d_{min}$	<1.25	1.25	1.5	2	2.5	3	3.5	4	4.5	5	5.5	6	7	8	10	12
3	a	0.783	0.800	0.833	0.867	0.900	0.933	0.967	1.000	b	b	b	b	b	b	b
4	a	a	a	0.800	0.825	0.850	0.875	0.900	0.925	0.950	0.975	1.000	b	b	b	b
6	a	a	a	a	0.783	0.800	0.817	0.833	0.850	0.867	0.883	0.900	0.933	0.967	b	b
8	a	a	a	a	a	a	0.788	0.800	0.813	0.825	0.838	0.850	0.875	0.900	0.950	1.000

a - $d_{min} < 0.4h_{ef}$ thus, side-face blowout governs (see Section D.5.4 of Appendix D, ACI 318-02).

b - $d_{min} > 1.5h_{ef}$ thus, stud group is no longer considered near that free edge (another case may govern).